**User's
Manual**

YEW SERIES 80

**Models SLPC
-151, -181
-251, -281 (Style E)
Programmable Indicating
Controller**

IM 1B4C2-04E

Notices

■ Regarding This User's Manual

- (1) This manual should be passed on the end user. Keep at least one extra copy of the manual in a safe place.
- (2) Read this manual carefully and fully understand how to operate this product before you start operation.
- (3) This manual is intended to describe the functions of this product. Yokogawa Electric Corporation (hereinafter simply referred to as Yokogawa) does not guarantee that the functions will suit a particular purpose of the user.
- (4) Under absolutely no circumstances may the contents of this manual in part or in whole be transcribed or copied without permission.
- (5) The contents of this manual are subject to change without prior notice.
- (6) Every effort has been made to ensure accuracy in the preparation of this manual. Should any error or omissions come to your attention however, please contact your nearest Yokogawa representative or our sales office.

■ Regarding Protection, Safety, and Prohibition against Unauthorized Modification

- (1) In order to protect the product and the system controlled by it against damage and ensure its safe use, make certain that all of the instructions and precautions relating to safety contained in this manual are strictly adhered to. Yokogawa does not guarantee safety if products are not handled according to these instructions.
- (2) Be sure to use the spare parts approved by Yokogawa when replacing parts or consumables.
- (3) Modification of the product is strictly prohibited.
- (4) Reverse engineering such as the disassembly or decompilation of software is strictly prohibited.
- (5) No portion of the software supplied by Yokogawa may be transferred, exchanged, leased or sublet for use by any third party without the prior permission of Yokogawa.

■ Force Majeure

- (1) Yokogawa does not make any warranties regarding the product except those mentioned in the WARRANTY that is provided separately.
- (2) Yokogawa assumes no liability to any party for any loss or damage, direct or indirect, caused by the user or any unpredictable defect of the product.

CONTENTS

<i>Section</i>	<i>Title</i>	<i>Page</i>
1.	INITIAL INSPECTION	1-1
1-1.	Confirm Model and Suffix Codes	1-1
1-2.	References	1-1
2.	INTRODUCTION	2-1
2-1.	Standard Specifications	2-1
2-2.	Model and Suffix Codes	2-3
2-3.	Optional Specifications	2-3
2-4.	Accessories	2-3
3.	INSTALLATION	3-1
3-1.	Wiring	3-1
4.	PRINCIPLES OF OPERATION	4-1
4-1.	Circuit Descriptions	4-1
4-2.	Principles of Computation and Control	4-1
5.	OPERATION	5-1
5-1.	Names and Functions of Components	5-1
5-2.	Preparations for Operation	5-8
5-3.	Start-Up and Operation	5-10
5-4.	Setting and Display of Self-Tuning Function	5-11
5-5.	Setting and Display of Adjustable Set-point Filter Function	5-14
5-6.	Automatic Control	5-15
5-7.	Actions to be Taken When FAIL and ALM Lamps Light Up	5-16
5-8.	Connecting an SPRG Programmer	5-19
6.	MAINTENANCE	6-1
6-1.	Test Equipment	6-1
6-2.	Test, Calibration, and Adjustment	6-1
6-3.	Parts Replacement	6-5
7.	TROUBLESHOOTING	7-1
7-1.	Troubleshooting Flowcharts	7-1
7-2.	Disassembling and Reassembling Procedures	7-9
●	Customer Maintenance Parts List	CMPL 1B4C2-04E
●	POWER SUPPLY TERMINALS for PANEL-MOUNTED INSTRUMENTS (for /HTB)	IM 1B4F1-11E

1. INITIAL INSPECTION.

This instrument was thoroughly factory-tested before shipment. When the instrument is received, however, check visually for any external damage that may have occurred during transit. Insure that it is complete with all standard accessories.

Read this section carefully before operating the SLPC Programmable Indicating Controller. For items not covered in this section refer to the appropriate sections in the manual.

1-1. Confirm Model and Suffix Codes.

The model and suffix codes are on the name-plate on the side panel of the instrument. Check them against the model and suffix codes given in Section 2-2 to make sure that the instrument meets your specifications.

If you have any questions about this instrument, please contact either your nearest Yokogawa Sales & Service Office or Yokogawa Electric Corporation, Tokyo, Japan.

1-2. References.

This instruction manual provides information about the handling of the SLPC Programmable Indicating Controller, its operational procedure, and simplified maintenance workflows.

To run the SLPC to fully support your applications, certain preparatory steps are required, including the processes of generating a program on instrumentation flow sheet forms and loading the resultant program in read-only memory (ROM).

Information on these operations is available in specific manuals.

Step 1: Information and material related to program generation.

- ① YS80 Programmable Indicating Controller Functions and Applications – Technical Information
TI 1B4C2-02E
- ② SLPC Worksheet
WS 1B4C2-11
- ③ SLPC Data Sheet
WS 1B4C2-12E
- ④ SLPC Data Sheet
WS 1B4C2-14
- ⑤ SLPC Program Sheet
WS 1B4C2-15
- ⑥ SLPC Control Module Seal

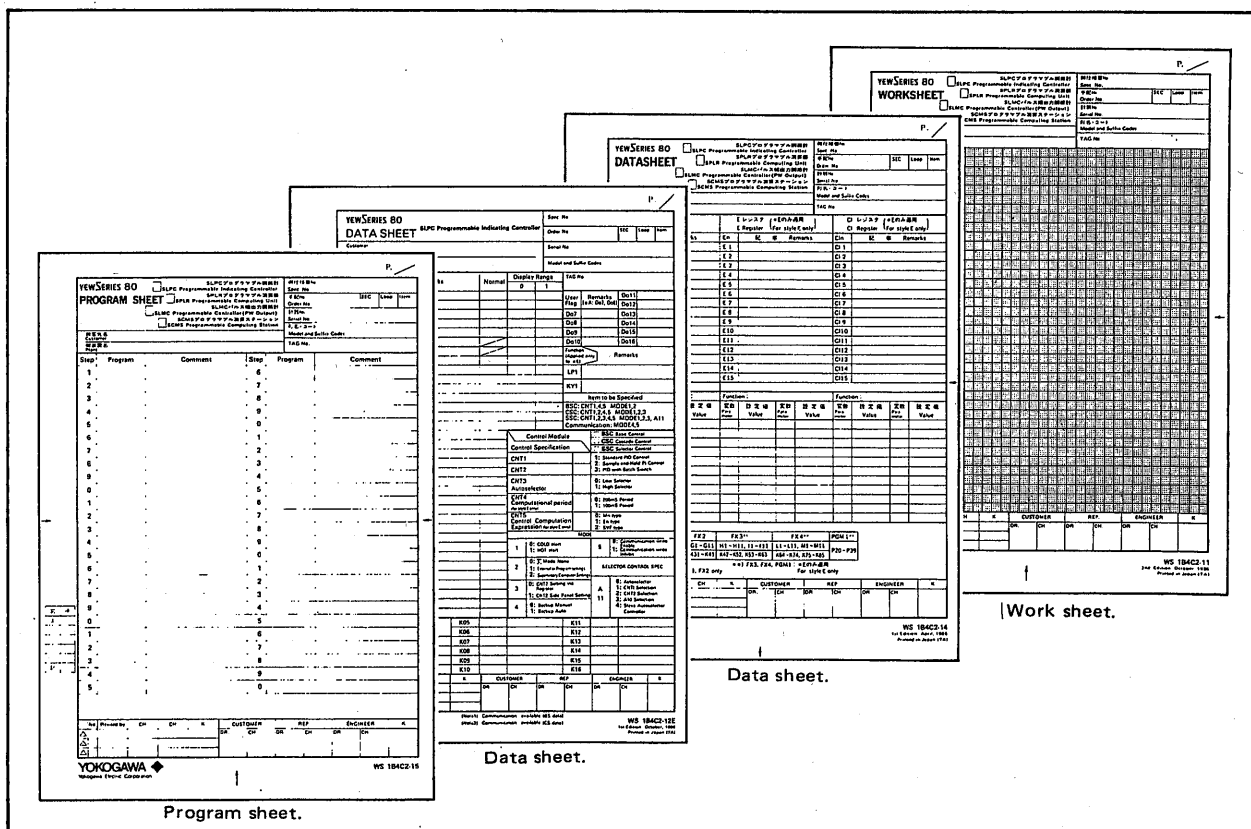

Figure 1-2-1. Forms Used in Step 1.

Step 2: Instruction manuals related to loading programs in ROM.

- ① SPRG Programmer Instruction Manual (Note) IM 1B4W1-02E
- ② YS80 Programmable Indicating Controller Functions and Applications TI 1B4C2-02E

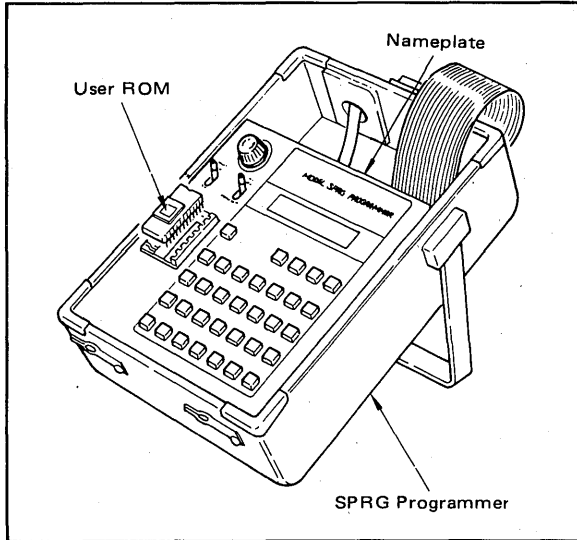

Figure 1-2-2. User ROM and SPRG Programmer.

Note: When the SPRG (Style A) programmer is used for programming, only the functions of the SLPC (Style A) programmable indicating controller [a subject of the functions of the SLPC (Style E)] can be programmed.

Step 3: Install the ROM in the SLPC and proceed with operations.

This instruction manual is concerned with the operations for step 3.

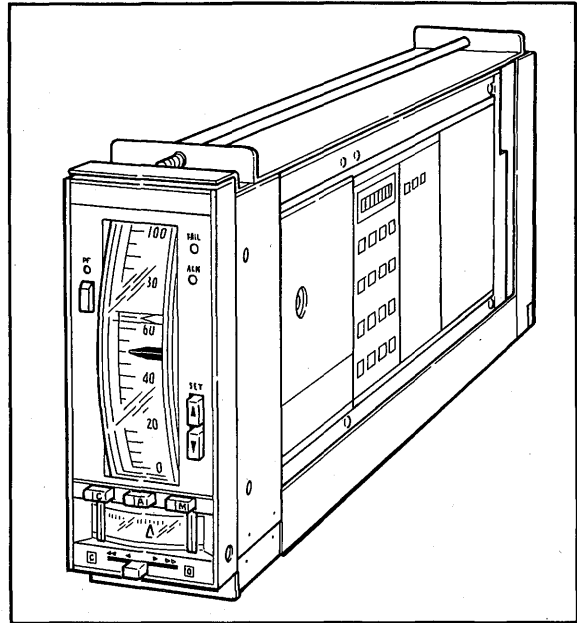

Figure 1-2-3. SLPC Programmable Indicating Controller.

2. INTRODUCTION.

The SLPC Programmable Indicating Controller is a microprocessor-based, user-programmable instrument which provides signal computation and control functions as well as sequence logic functions.

In addition to simple PID control, batch control and sample-and-hold PI control, the SLPC's control functions include variable-gain control and dead-time compensation control; and a single SLPC can simulate two controllers in a cascade control or autoselector control configuration.

A new intelligent self-tuning model automatically optimizes PID parameters.

A user-adjustable set-point filter, used to improve the response to set-point changes, is also provided as a standard feature.

There are about 46 different computational and (sequence) logic functions; these can be freely combined to create user-defined functions. And, by using subprograms, even "large" or complex application programs can be easily realized.

The SLPC controller is as easy to program as an electronic calculator. It is programmed by connecting it to an SPRG programmer.

2-1. Standard Specifications

Input/Output Signals

Analog Input Signal: 1 to 5 V DC, 5 points.

Analog Output Signal: 1 to 5 V DC, 2 points
4 to 20 mA DC, 1 point.

Status Input Signal: Contact or voltage level

Status Output Signal: Transistor contact
6 points (user-defined as output or input)

Fail Output Signal: Transistor contact, 1 point

This contact output is open in the fail state (also open when power fails).

Indication/Setting/Operation Functions

Process Variable and Set-Point Indicators:

Dual pointer moving coil meter or fluorescent bar graph indicator, plus a four-digit numeric display.

Output Indicator: Moving coil indicator.

Setting Methods:

Manual Setting: Setting speed 40 sec./full scale.

Remote Setting: By input signal or computation.

Control Mode Switching: By C/A/M switches or a user-programmed definition.

Manual Output Operation: Two-speed lever action.

Parameter Setting and Data Display: From tuning panel (side panel).

Programmable Function Key (PF key): 1 key (which can be used as status input signal).

PF Lamp: 1 lamp (which can be turned on/off by user program).

Control Functions

Control Modules:

Basic Control Module: A single control module.

Cascade Control Module: Two control modules connected in cascade. One SLPC controller can implement a cascade loop. An arithmetic computation may be performed between primary and secondary controllers.

Signal Selector Control Module: Two control modules connected in parallel. One SLPC controller can implement an autoselector control loop.

Functions in Common in the Modules above: Output tracking, output limiter.

Control Elements:

A Control Module Comprises One of Three Control Elements: Basic PID control element, Sample-and-Hold PI control element or PID control element with batch switch. These control elements, described above, may contain the following common functions: Process variable high/low limit alarms, velocity limit alarm, deviation alarm, set point transmission, input compensation signal addition, nonlinear control, variable gain, feedforward signal addition.

Adjustable Filter for Set-Point Changes:

Response to setpoint changes can be adjusted.

Two adjustment parameters (for each set point).

Self-tuning Function (in SLPC-□81) Features:

Self-tuning selector (ON/OFF) switch (can be operated manually or by user program),

Limits can be set for tuning of PID parameters.

Control and Computational Periods: 0.2 or 0.1 seconds.

Computational Functions

Functions	Function name	Max. no. of times function may be used in program
General functions	Addition, Subtraction, Multiplication, Division, Magnitude (absolute value), Square root with "low-signal cutoff", High selector, Low selector, High limiter, Low limiter	— — — — — —
	10-segment transfer function (user-definable break points) (two functions)	2
	Transfer function with user-definable number of segments	2
	High limit alarms	4
	Low limit alarms	4
Functions with unit addresses	First-order lag	8
	First-order lead	2
	Dead-time, velocity computations and moving average	3 total
	Velocity limiter	6
	Timers	4
	Program set unit	1
	Detection of status change	8
	Pulse input counter	4
	Pulse rate output	2
	Logical functions	AND, OR, XOR, NOT, CMP (test if greater than or equal)
Branching, Conditional branching		—
Subroutine calls		—
Signal switching		—

Note: Where limits are indicated by a dash "—" above, this means that there is no preset limit.

Communication Functions

The SLPC can communicate (via an LCS card in YEWPACK, μ XL/CENTUM) with a central YEWPACK, μ XL/CENTUM CRT-display operator station. The SLPC can also communicate with an SCMS Programmable Computing Station. (The SLPC can be connected to both an LCS card and SCMS). The maximum length of cable (SCCD cable) to LCS card or SCMS computing station is 100 m (328 ft).

Mounting:

Flush panel mounting. Instruments are in housings, and may be mounted individually or side-by-side.

The instrument may be tilted in the front up to 75° from vertical (rear of instrument lower than front). (Zero indicator may need readjustment).

Wiring:

Signal Wiring to/from the Field: ISO M4 size (4 mm) screws on terminal block.

Power and Ground Wiring:

100 V version: JIS C 8303 two-pin plug with grounding (IEC A5-15, UL498).

220 V version: CEE 7 VII (CENELEC standard) plug.

Power Cable Length: 30 cm (11.8 in).

Housing Dimensions: 182.5 (H) × 87 (W) × 480 (D: depth behind panel) (mm) (7.2 × 3.4 × 18.9 in).

Weight:

Controller Unit: 3.4 kg (7.5 lb).

Housing: 2 kg (4.4 lb) (excluding mounting kit).

Normal Operating Conditions

Ambient Temperature: 0 to 50°C (32 to 122°F).

Ambient Humidity: 5 to 90% Relative Humidity (non-condensing).

Power Supply: Two versions, for "100 V" (standard) or "220 V" (optional /A2ER). Both versions may use AC or DC, without change to the instrument:

Version	100V	220V
DC (polarity reversible)	20 to 130V	120 to 340V
AC (47 to 63Hz)	80 to 138V	138 to 264V

2-2. Model and Suffix Codes.

Model	Suffix codes	Style	Option codes	Description
SLPC	Programmable Indicating Controller
Indicator	-1	Moving coil
	-2	Fluorescent bar graph*2
Functions	5	Enhanced model, with adjustable filter
	8	Enhanced model, with adjustable filter and self-tuning function
	1	Always 1
Style code		*E	Style E
Options			/NPR /UPR	Unprogrammed With user program
Common options			/A2ER	220V power supply*1
			/MTS	With mounting kit
			/SCF	Bezel color change
			-G□M	
			/NHS /NPE	Without housing Nameplate engraving

*1 Specify /A2/NHS to order without housing.

*2 The order acceptance of fluorescent bar graph is discontinued.

2-3. Optional Specifications.

/NPR: Controller supplied unprogrammed (with blank EPROM). The user can write his program to EPROM using a SPRG Programmer.

/UPR: Controller supplied with user program prepared in YOKOGAWA M&C configuration.

/A2ER: For "220 V version" power supply.

/MTS: Controller supplied with kit for separate mounting.

/SCF-G□M: Mounting kit bezel color change from standard color (black). Choose color from set of optional colors (see GS 22D1F1-E). Specify color code in space □.

/NHS: No housing, instrument only. See GS 1B4F1-E to order housing separately.

/NPE: Letters engraved on front panel nameplate.

2-4. Accessories.

Fuse (1 A): 1 piece. Part No. S9510VK

ROM: 1 module. (When NPR is selected, the controller is supplied with blank ROM.)

Part No. A1123LQ

Note: The fuse (S9510VK) is the dedicated fuse, Do not use it for other products.

3. INSTALLATION.

For general information on installation and mounting, refer to the Instruction Manual, "Panel Instrument Mounting" (IM 1B4F1-01E).

3-1. Wiring.

Connect external signal wires to the terminal board on the rear of the controller housing with M4 (4 mm) size screws. Remove the cover from the housing for access to the terminal board. Place the cover in its original position after wiring. (See Figures 3-1-1 and 3-1-2.)

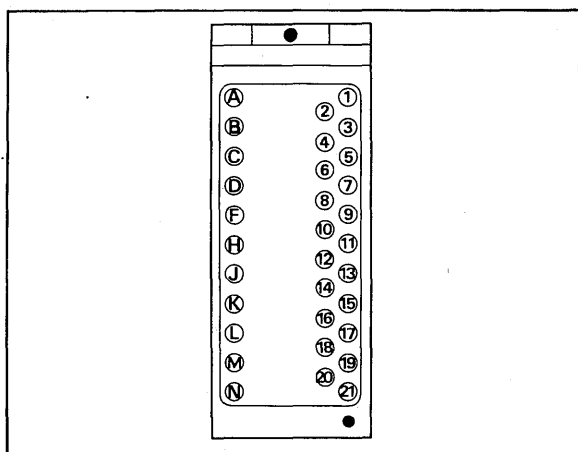

Figure 3-1-1. Terminal Layout.

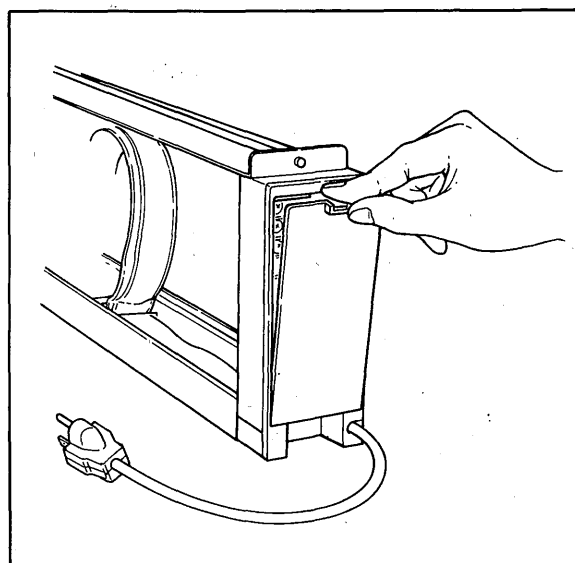

Figure 3-1-2. Terminal Board Cover.

Table 3-1-1 shows the terminal designations and signals to be connected to the SLPC Programmable Indicating Controller.

■ Terminal Connections

Table 3-1-1. Terminal Connections.

Terminal Designation	Description	Terminal Designation	Description
1	+ > Analog input 1	17	+ > Communications (Note 2)
2	- > Analog input 1	18	- > Communications
3	+ > Analog input 2	19	+ > Status signal 4 (IN4, OUT3)
4	- > Analog input 2	20	- > Fail (negative terminal)
5	+ > Analog input 3 (Note 1)	21	- > Fail (negative terminal)
6	- > Analog input 3 (Note 1)	A	+ > Analog output 1 (current output)
7	+ > Analog input 4 (Note 1)	B	- > Analog output 1 (current output)
8	- > Analog input 4 (Note 1)	C	+ > Analog output 2
9	+ > Analog input 5	D	- > Analog output 2
10	- > Analog input 5	F	+ > Analog output 3
11	+ > Status signal 1 (IN1, OUT6)	H	- > Analog output 3
12	- > Status signal 1 (IN1, OUT6)	J	+ > Status signal 6 (IN6, OUT1)
13	+ > Status signal 2 (IN2, OUT5)	K	- > Status signal 6 (IN6, OUT1)
14	- > Status signal 2 (IN2, OUT5)	L	+ > Status signal 5 (IN5, OUT2)
15	+ > Status signal 3 (IN3, OUT4)	M	- > Status signal 5 (IN5, OUT2)
16	- > Status signal 3 (IN3, OUT4)	N	+ > Fail (positive terminal)

Note: 1. A jumper is attached between terminals 6 and 8. Use it to short terminals A and B when current output is not used. Terminals 6 and 8 have no effect on instrument operation and can be shorted or left open.

2. Use shielded twisted-pair SCCD cables for communication lines.

3-1-1. Wiring Instructions.

- (1) Be sure to use solderless crimp-on lugs on all cable connections.
- (2) Each status (contact) and voltage input must be of the proper rating. Note the limits on leadwire resistance, voltage drop across leadwires, and voltage (high/low) levels.
- (3) The fail and status (contact) outputs are transistor contact signals (isolated from power supply and other internal circuitry). When connecting external devices, pay attention to the following (see Figure 3-1-3):
 - Observe correct polarity of contact output terminals.
 - When connecting a relay or other inductive device, connect a surge absorber (protective

diode, CR circuit, etc.) in parallel with the load.

- Note that transistor contacts cannot be connected directly to an AC circuit. Use a relay to switch an AC circuit.
 - Do not connect any load which exceeds the contact rating (30 V DC, 200 mA).
- (4) The status (contact) inputs and outputs are designated by program, so wire them after confirmation of the program. If not designated, status (contact) signals 1 to 3 are input (DI) and status signal 4 to 6 are output (DO).
 - (5) Use shielded twisted-pair SCCD cables for communication lines (terminals 17 and 18).
 - (6) Short current output terminals not in use.

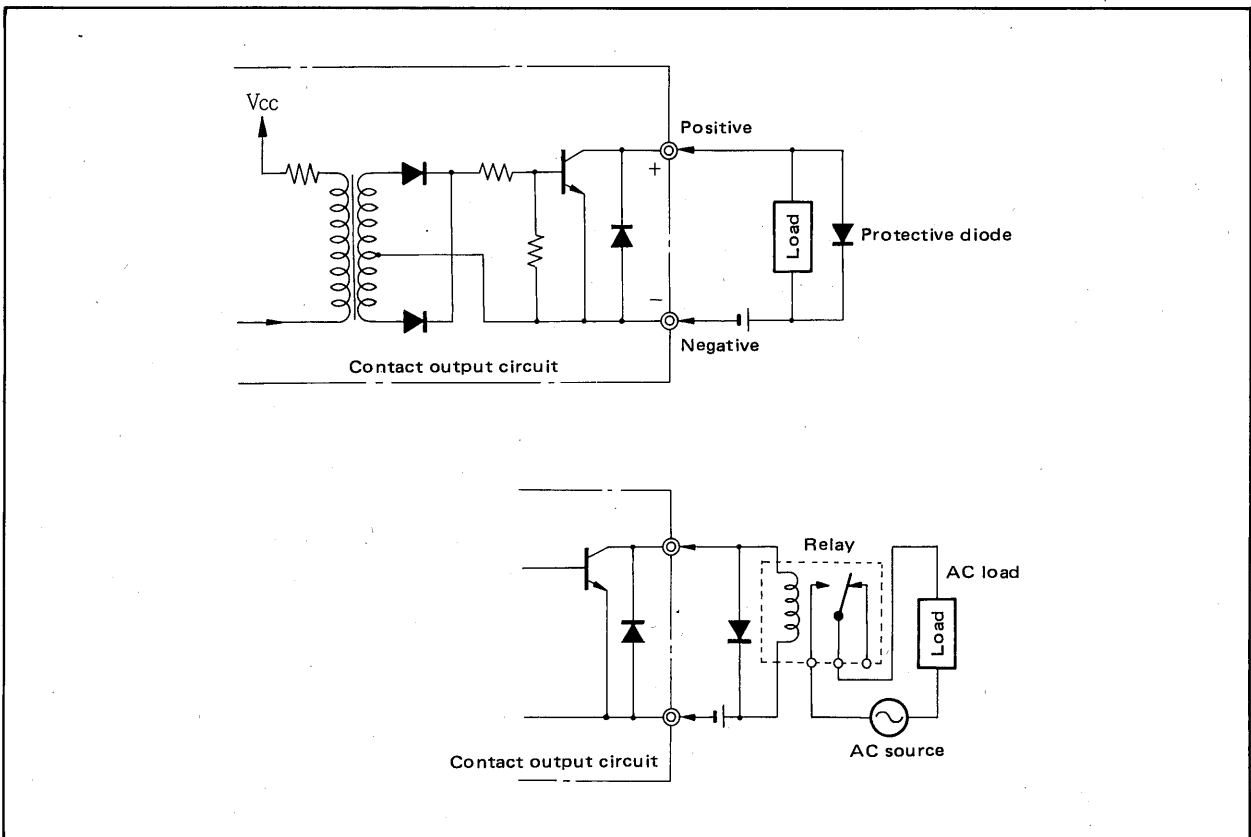

Figure 3-1-3. Contact Output Connections.

4. PRINCIPLES OF OPERATION.

4-1. Circuit Descriptions.

See the SLPC circuit block diagram on page 4-4.

4-1-1. Analog Input Circuit.

A voltage input signal enters the input circuit consisting of RIN, RI, and CI. RIN uses a high value of resistance (1 MΩ), so it normally does not affect circuit operation. However, if the input circuit opens (input is disconnected), it provides a DC path between (+) and (-) input terminals to prevent the buildup of static charge on the (+) input line. 0 V DC input (e.g., input is open) is equivalent to -25% of the range.

RI and CI form an input filter with a time constant of approximately 0.1 sec.

All analog-input negative leads are connected to a common line inside the SLPC.

4-1-2. Analog-to-Digital Converter Circuit.

Analog input signals entering the input circuit are sequentially selected by the input multiplexer. The comparator compares an input signal with the output of the digital-to-analog converter circuit, and the CPU adjusts the converter output so that the two signals are equal — basically, a successive-approximation type of analog-to-digital converter. The corresponding digital value is stored in data memory (RAM).

4-1-3. Digital Input Circuit.

Each digital (status) input signal is isolated by a transformer in the input circuit. Input status is read via an input port and transmitted via the data bus to RAM. (When the circuit is designated for input by a program).

At the same time as the digital input are read, the switch status (SET, C/A/M, MV, PF, TUNING, ACTION) on the instrument front and side panels is also read and stored in RAM.

4-1-4. Digital Computing Circuit.

When all the input data is read, the microprocessor (CPU) carries out data processing according to the computation/control program stored in User ROM.

The results of computation and control are output via the digital-to-analog converter circuit or output ports.

If a supervisory system is connected, data communications is performed via a loop communication card (LCS). The communications line is isolated from the controller by a photocoupler.

The watch-dog timer (WDT) connected to the CPU supervises the CPU operation — it causes the FAIL lamp to light up and outputs a fail contact signal if the CPU fails. If the CPU fails, the manipulated output current signal (Y1) is automatically isolated from the digital circuit, and can be varied manually. The measurement indicator then automatically indicates the value of input signal No. 1 (X1).

4-1-5. Analog Output Circuit.

The analog output signals, after digital-to-analog conversion, are fed via the output demultiplexer and buffer amplifier to the current and voltage output circuits.

The analog output signal negative line is common, and is connected directly to the analog input signal common negative line.

4-1-6. Digital Output Circuit.

The digital output signals are transformer-isolated and output to the field as open-collector contact signals. (When the circuit is designated for output by a program).

4-2. Principles of Computation and Control.

4-2-1. Principles of Computation.

The SLPC performs three basic operations. It reads the input signal, computes, and outputs the computed result. The example in Figure 4-2-1 shows how to program the addition of two input signals. Figure 4-2-2 shows how the stack registers S-change during the program. All computations are performed in the common stack registers S. Connection of signals to the registers — that is, input to the S registers — is performed by means of the LOAD (LD) instruction. The S registers, S1 thru S5, comprise a "stack," and data in S is pushed down (S1 to S2, S2 to S3, and so on) each time new data is input by the LD instruction.

Arithmetic operations can be performed on data thus input by using FUNCTION instructions. There are approximately 46 different computational and control FUNCTION instructions. These instructions are entered using their associated symbols, such as +, ÷, and HSL. The result of a computation performed on the necessary number of data stored in S registers is popped up to top register S1.

The STORE (ST) instruction is used to retrieve the result of computation and store it in an output register (to be described later). Execution of the ST instruction does not affect the contents of the S registers.

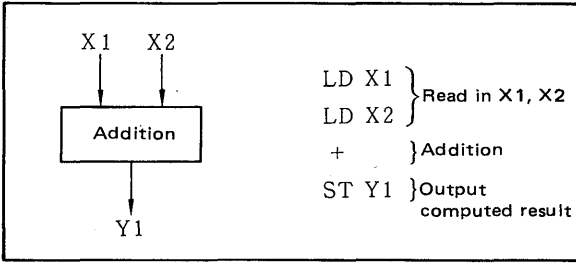

Figure 4-2-1. Two-Input Adder and Program.

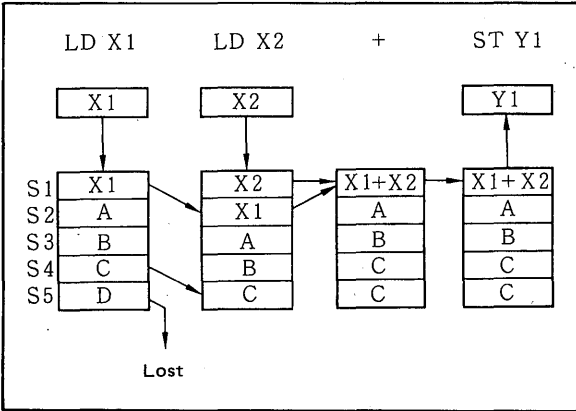

Figure 4-2-2. Behavior of Arithmetic Registers Associated with the Sample Program.

4-2-2. Input/Output Register Configuration.

Figure 4-2-3 shows the configuration of the SLPC's input/output registers. Analog, digital, and set parameter inputs are read into registers X_N , DIN , and P_N before execution of the user program begins. The user program reads required input signals and parameters from the respective input registers into the arithmetic register using the LD instructions, and stores the computed results in output registers Y_N and DO_n using ST instructions. Finally, the controller outputs the contents of output registers Y_N and DO_n as analog or digital values. This cycle repeats itself every 0.2s or 0.1s.

4-2-3. Principles of Operation of Control Modules.

The SLPC Indicating Controller incorporates three control modules:

- Basic control module (BSC), which consists of one controller contained in a single module.
- Cascade control module (CSC), which consists of two controllers combined in series.
- Signal selector control module (SSC), which consists of two controllers combined in parallel, selects one of three signals: either one of two controller outputs or an input signal.

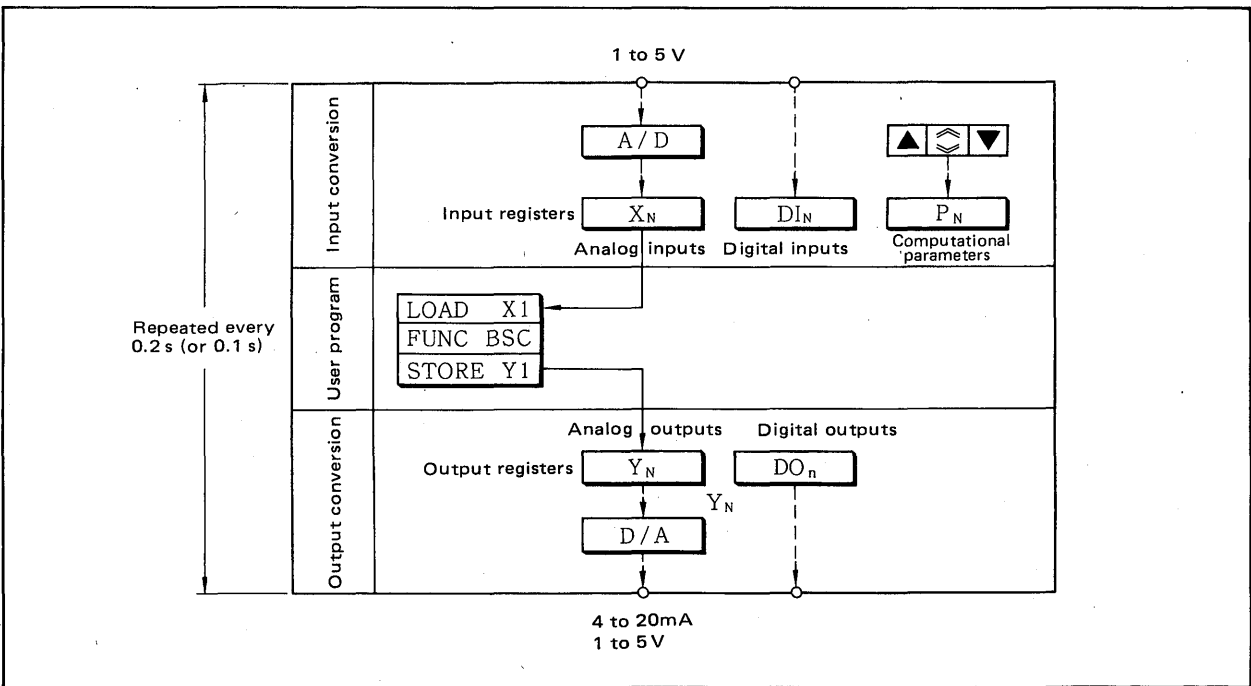

Figure 4-2-3. Input/Output Register Configuration.

A program to operate the SLPC as a PID controller is very simple, as shown below:

1. LD X1
2. BSC
3. ST Y1
4. END

A variety of options can be used with the BSC controller, as shown in Figure 4-2-4. These functions can be utilized by using A, B and FL registers in programs.

In cascade control mode, for example, an ST instruction is used to store the cascade set point input value in A1. When a feedforward compensation is required, the feedforward signal is stored in A4. The high or low alarm status can be output by storing the contents of FL1 and FL2 in DO_n (digital output) registers.

Optional functions defined by certain A registers and FL registers are initialized to "OFF" status, and these registers may be simply ignored if the optional functions are not required.

"Control elements" such as standard PID, sample-and-hold PI, and PID controller with batch switch can be selected.

With the cascade control module CSC, the SLPC functions as two controllers in cascade. The cascade loop can be opened or closed from the side panel keyboard. With the selector control module SSC, the SLPC can function as an autoselector controller or as a tracking controller which can select and output one of several input signals. As the CSC and SSC functions incorporate two built-in control elements, the front panel displays the set point, process variable and manipulated variable of the first element, and the side panel displays those of the second.

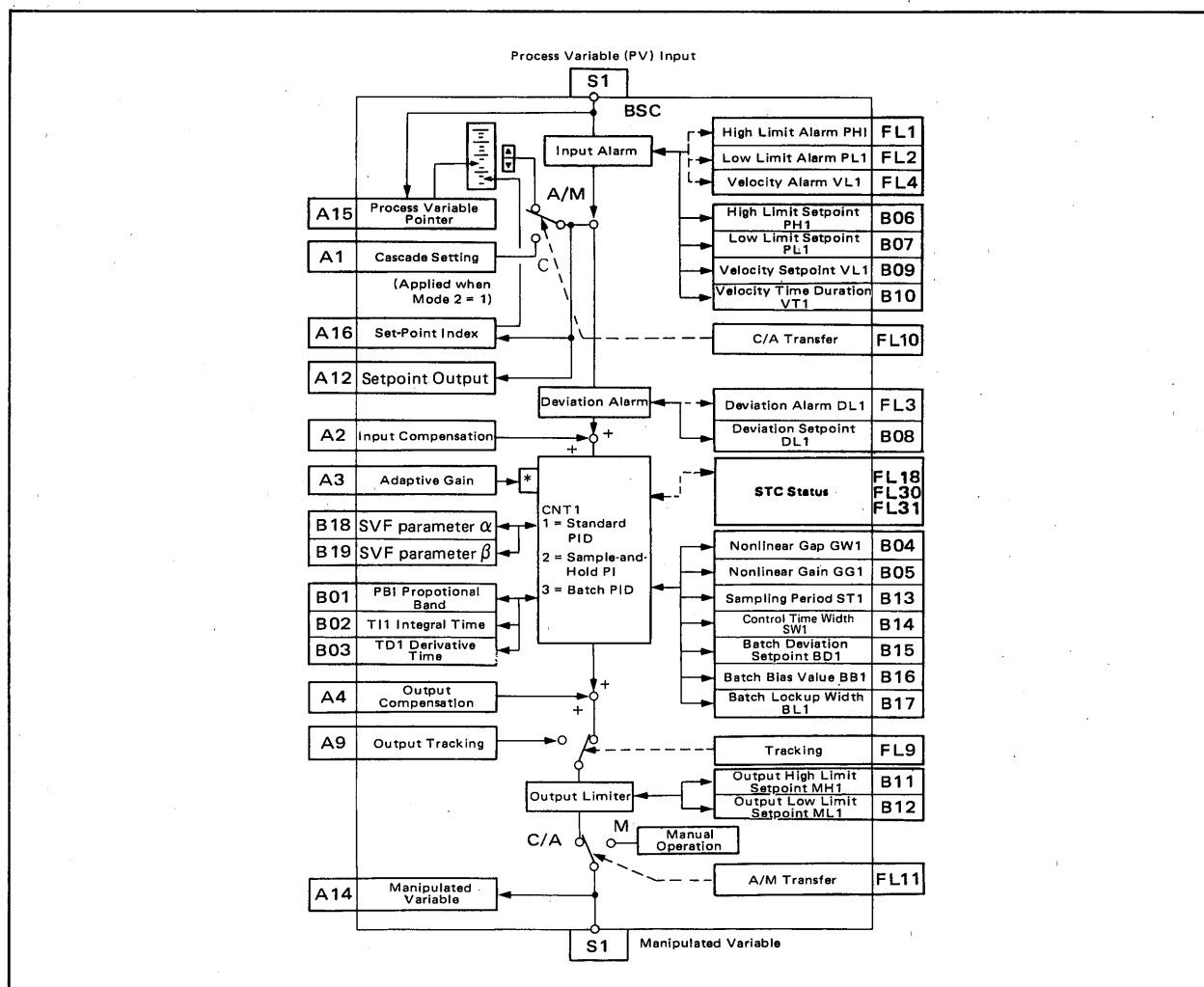
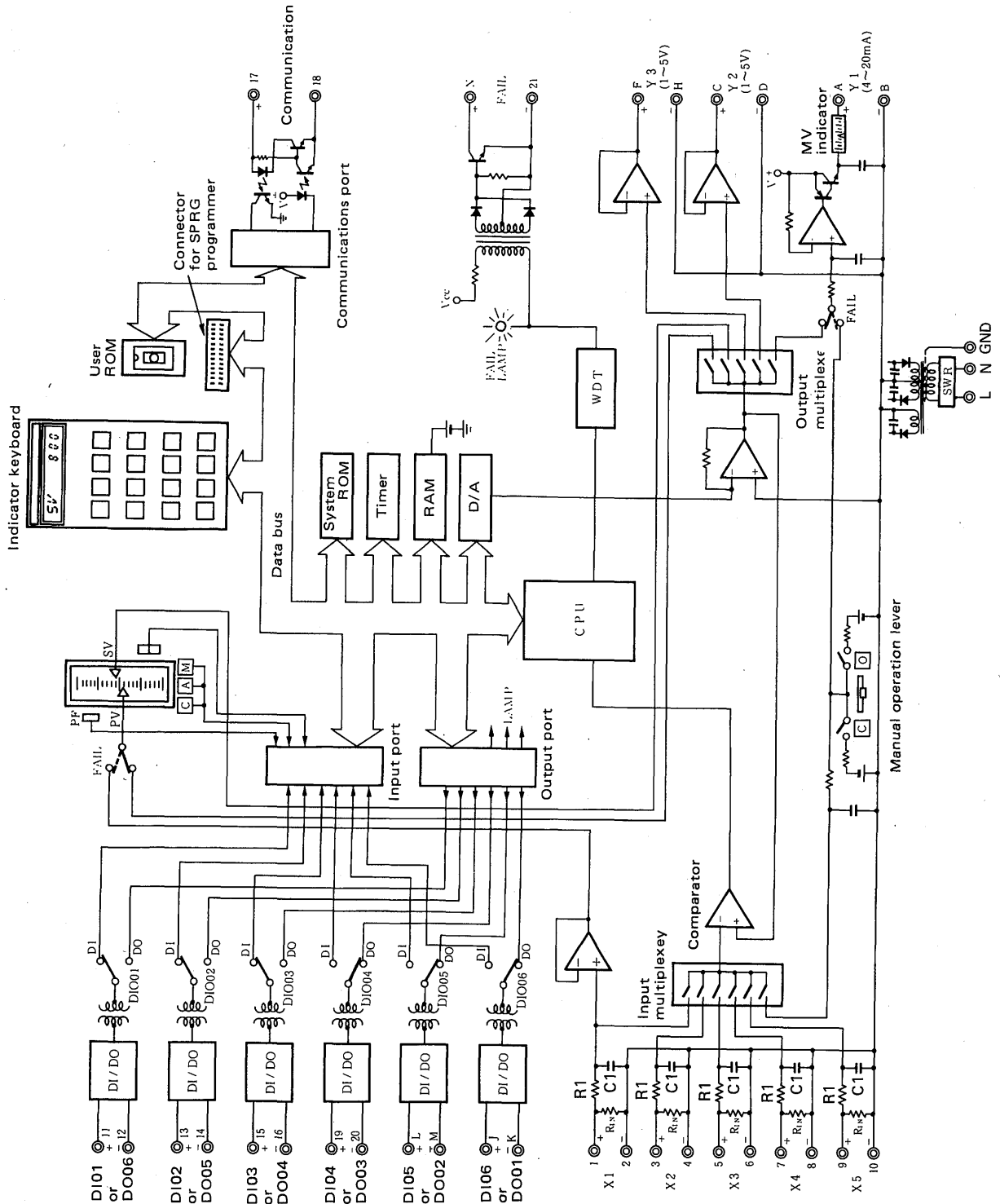

Figure 4-2-4. BSC Functional Block Diagram.

■ SLPC Circuit Block Diagram



5. OPERATION.

5-1. Names and Functions of Components.

5-1-1. Controller with Moving Coil Indicator.

This controller uses a moving coil indicator for indicating the process variable and setpoint. Figure 5-1-1 shows the front view of this type of controller (SLPC-171*E), and Figure 5-1-2 shows the side view of the controller. The names of panel controls, and other components are also shown in these Figures.

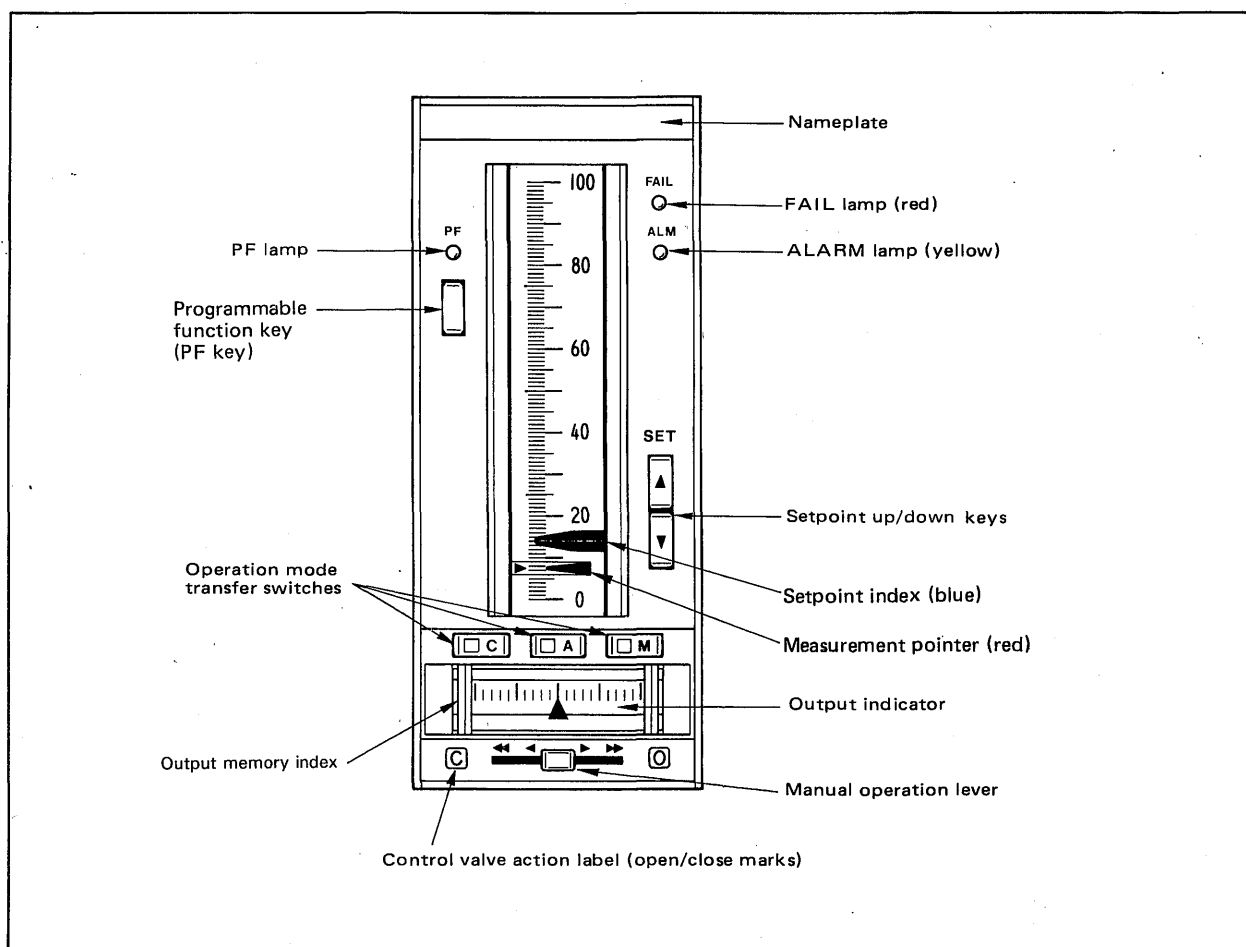

Figure 5-1-1. Controller Front View.

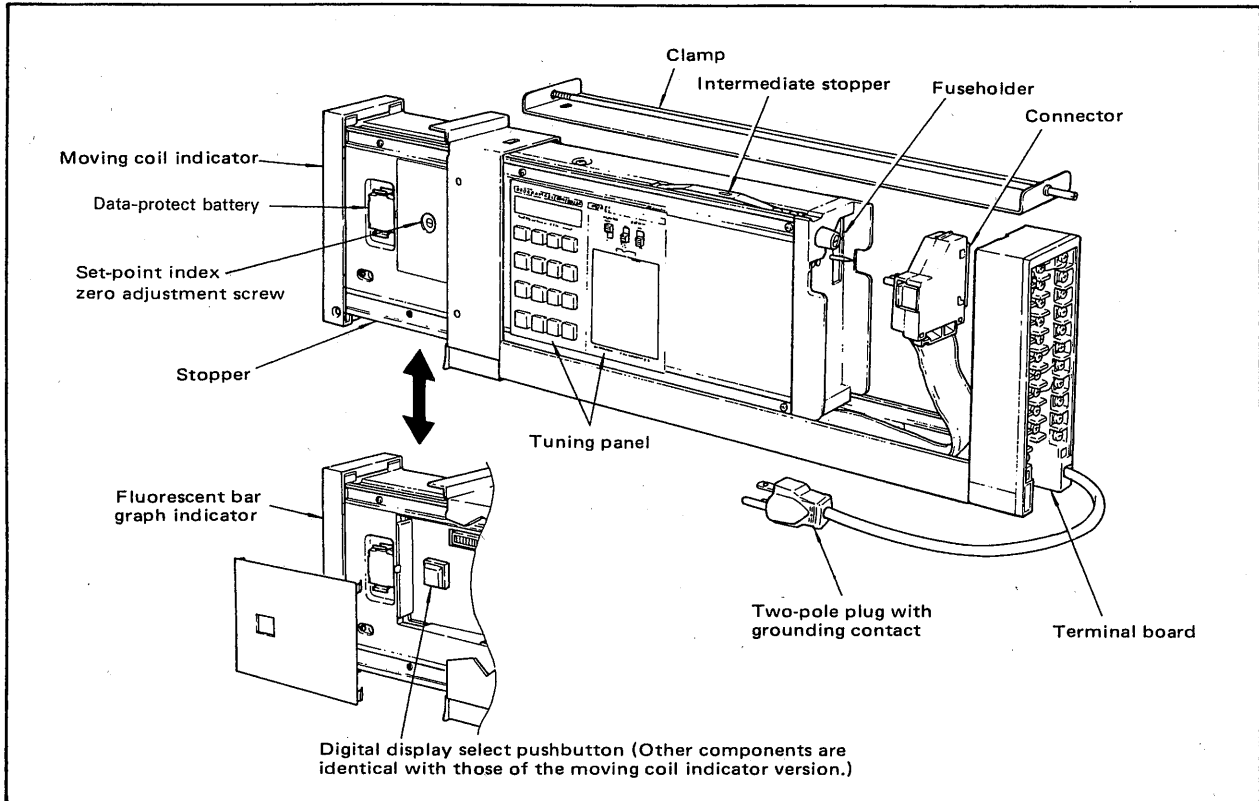

Figure 5-1-2. Controller Side View.

(1) FAIL lamp

Lights up when the controller fails.

(2) ALM lamp

Lights up to indicate the establishment of an alarm condition, and flashes when data-protect battery voltage drops.

(3) Measurement pointer

Indicates the value of the process variable*.

(4) Setpoint index

Indicates the value of the setpoint**.

(5) Setpoint up/down keys

Used for adjusting the setpoint**. Operable while in A (auto) or M (manual) mode.

Setting:

To increase setpoint, press ▲ key

To decrease setpoint, press ▼ key

(The setpoint remains unchanged when the two keys are pressed at the same time.)

Setting rate: 40 sec./full scale.

Fine adjustment: Pressing the key momentarily (for approx. 0.2 sec.) changes the setpoint by 0.1%.

(6) C/A/M mode transfer switches

The desired operation mode can be selected by pressing the appropriate pushbutton. The pushbutton built-in indicator lamp lights up.

C mode: Automatic control. The setpoint** is set using the computational functions, or by communications data.

A mode: Automatic control. The setpoint** is set by using the SET pushbutton switches.

M mode: Manual control. The manipulated output signal can be increased or decreased by using the manual operation lever. The setpoint** can also be adjusted.

(7) Output indicator

Indicates readings of the current output signal in the range 4 to 20 mA DC.

(8) Manual operation lever

Used for adjusting the manipulated output signal of the controller in M mode.

Action:

Moving the lever to the left decreases the signal output, while moving it to the right increases the signal output.

Setting rate:

◀, ▶ 40 sec./full scale

◀◀, ▶▶ 4 sec./full scale

Fine adjustment:

Moving the lever from the neutral position to the left ◀ or right ▶ momentarily (for approx. 0.2 sec.) changes signal output by 0.1%.

* For cascade or signal selector control: Process variable of the first control element (CNT1).

** For cascade or signal selector control: Setpoint of the first control element (CNT1).

(9) Programmable function key (PF key)

When this key is pressed for about 0.2 seconds, it

acts as a status (contact) input signal (by user-programmed definition).

(10) PF lamp

This lamp can be lit or turned off by user program.

5-1-2. Controller with Fluorescent Bar Graph Indicator.

This controller uses a fluorescent bar graph indicator for indicating the process variable and setpoint. Figure 5-1-3 shows the names of front panel controls of this type of controller (SLPC-270*E). For a side view of the instrument, see Figure 5-1-2.

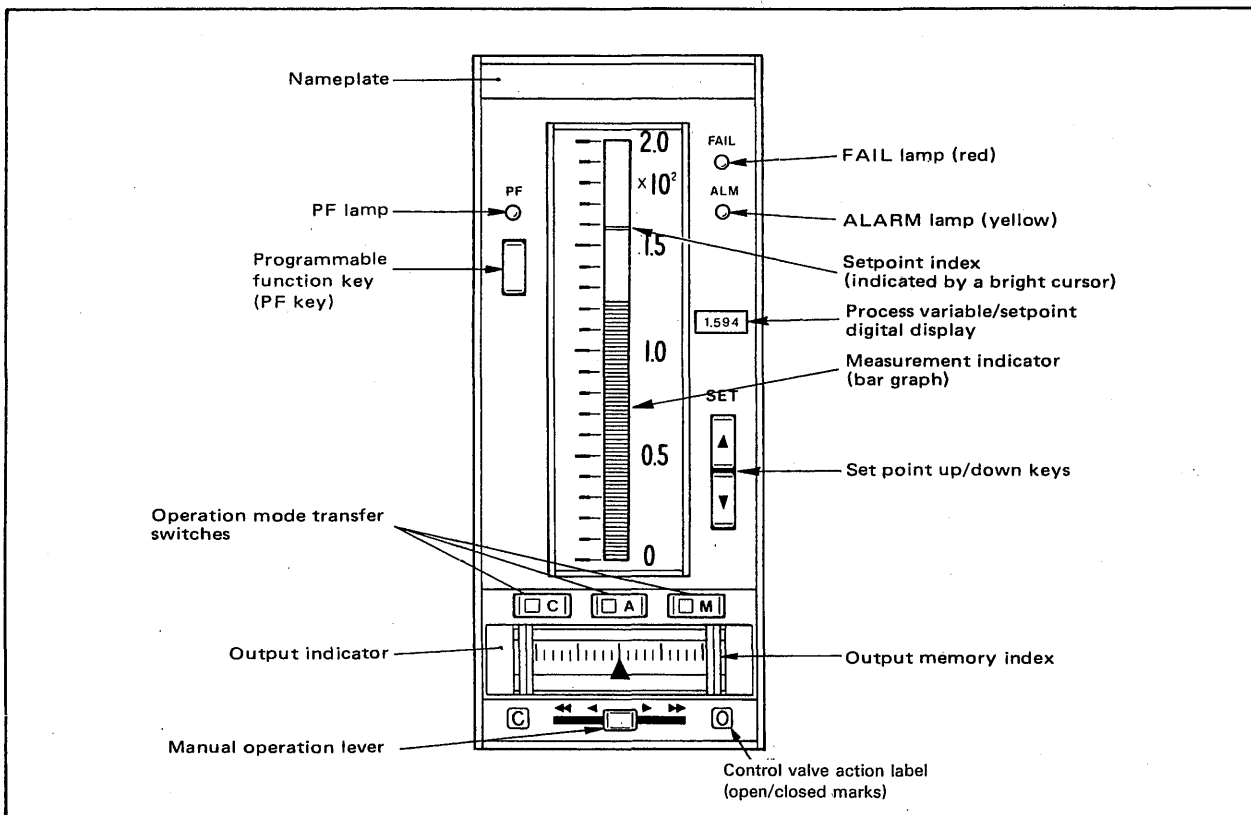

Figure 5-1-3. Controller Front View.

(1) Bar graph display

Displays the value of the process variable* as a bar graph.

(2) Setpoint index cursor

Indicates the setpoint** of the controller with a bright cursor.

(3) Digital display

Displays the value of the process variable as a 4-digit number in the appropriate engineering unit. The setpoint is displayed while the side-panel digital display select pushbutton is pressed. (See Figure 5-1-4.)

* For cascade or signal selector control: Process variable of the first control element (CNT1).

** For cascade or signal selector control: Setpoint of the first control element (CNT1).

Other functions are identical with those described in Section 5-1-1.

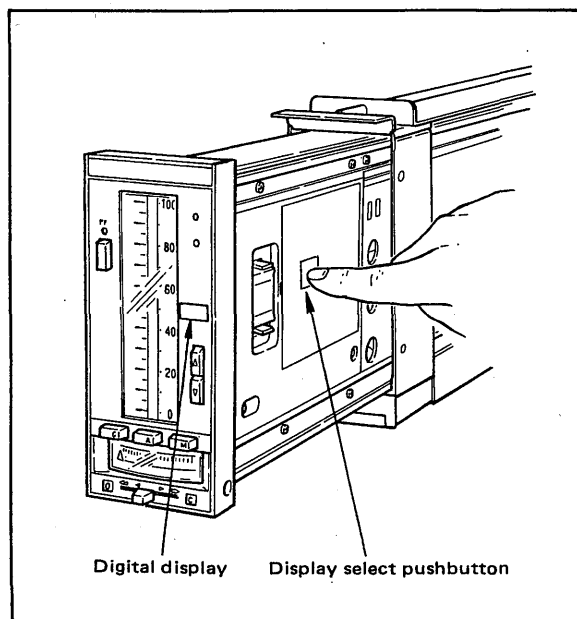

Figure 5-1-4. Digital Display Select Pushbutton.

5-1-3. Names and Functions of Tuning Panel.

■ Panel layout

The tuning panel for parameter setting and data display is on the right side of the SLPC Programmable Indicating Controller. (See Figure 5-1-5.)

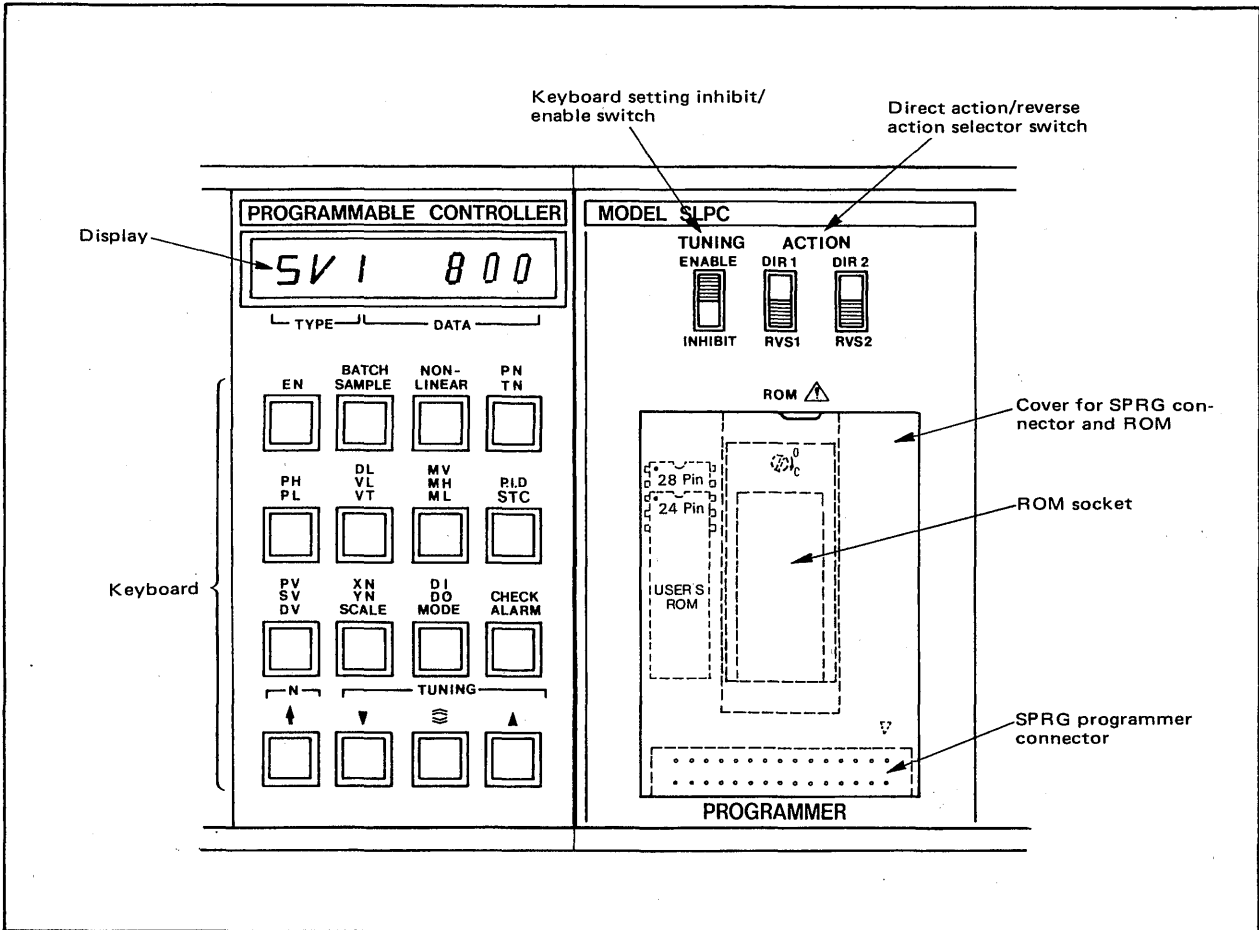
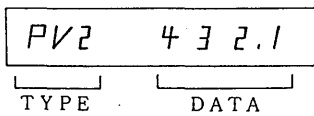

Figure 5-1-5. Tuning Panel.

(1) Display

Displays the data type code (TYPE) and data value (DATA) of the data entered from the keyboard.

(Display example)



(2) Keyboard

Used for entering parameters, displaying and changing data, and so on. The names and functions of the keyboard switches are summarized in Tables 5-1-1 and 5-1-2.

Table 5-1-1. Names and Functions of Tuning Panel Keyboard Switches.

Keyboard Display	Type (TYPE)	Number (N)	Name - Description	Display/Setting Range	Unit	Setting	Default Value	
EN	EN	1 to 15	E registers	-800.0 to 800.0	%	x	-	
	CI	1 to 15	CI registers	0/1	-	x	-	
	DN	1 to 15	D registers	-800.0 to 800.0	%	x	-	
	CO	1 to 15	CO registers	0/1	-	x	-	
BATCH	BD	1	Control parameters for PID with batch switch Deviation set point	0 to 100.0	%	O	0.0	
	BB	1	Bias value	0 to 100.0	%	O	0.0	
	BL	1	Lockup width	0 to 100.0	%	O	0.0	
	SAMPLE	ST	1, 2	Sample-and-hold PI control parameters Sample times (periods)	0 to 9999	sec	O	0
SW		1, 2	Control times	0 to 9999	sec	O	0	
NON-LINEAR	GW	1, 2	Non-linear control or 10-segment function parameters Non-linear control: dead-band width	0.0 to 100.0	%	O	0.0	
	GG	1, 2	Non-linear control: gain	0.000 to 1.000	-	O	1.000	
	F	1 to 11	10-segment line segment function output set points	0.0 to 100.0	%	O	Linear setting of 0.0 to 100.0	
	H	1 to 11						
	I	1 to 11	Arbitrarily-segmented line segment functions	-25.0 to 125.0	%	O		
	L	1 to 11						
	M	1 to 11						
PN	PN	1 to 8	Computational parameters	Engineering units display	-	O		0.0
		9 to 16	Computational parameters	-800.0 to 800.0	%	O		0.0
		20 to 29	Program setting (time)	0 to 9999	sec	O	0	
		30 to 39	Program settings (output value)	-25.0 to 125.0	%	O	0.0	
	(Note 1)	TN	1 to 16	Temporary storage registers	-800.0 to 800.0	-	x	-
PXN		1, 2	Adjustable set-point filter parameter α	0.000 to 1.000	-	O	0.000	
PYN		1, 2	Adjustable set-point filter parameter β	0.000 to 1.000	-	O	0.000	
PZN		1, 2	Not used	-	-	-	-	
PH	PH	1, 2	Process variable: high limit alarm set point	Engineering units using SCALE	-	O	106.3	
	PL	1, 2	Process variable: low limit alarm set point	Engineering units using SCALE	-	O	-6.3	
DL	DL	1, 2	Deviation alarm set point	Engineering units using SCALE	-	O	100.0	
	VL	1, 2	Velocity alarm: MV Change in time VT	Engineering units using SCALE	-	O	100.0	
	VT	1, 2	Velocity alarm: Time duration	1 to 9999	sec	O	1	
MV	MV	1	Manipulated variable	-6.3 to 106.3	%	O	-	
	MH	1, 2	Manipulated variable: High limit setpoint	-6.3 to 106.3	%	O	106.3	
	ML	1, 2	Manipulated variable: Low limit setpoint	-6.3 to 106.3	%	O	-6.3	
P.I.D	STC	-	STC mode designation	Refer to Section 5-4.	-	O	-	
	PB	1, 2	Proportional band	6.3 to 9999	%	O	999.9	
	TI	1, 2	Integral time	1 to 9999	sec	O	1000	
	TD	1, 2	Derivative time	0 to 9999 (Note 3)	sec	O	0	
(Note 2)	IP to GM		STC parameters	Refer to Section 5-4.	-	O	-	
PV	PV	1, 2	Control: process variable input value	Engineering units using SCALE	-	x	-	
	SV	1, 2	Control: set point	Engineering units using SCALE	-	O	-	
	DV	1, 2	Control: deviation value	Engineering units using SCALE	-	x	-	
SCALE	XN	1 to 5	Analog input registers	Engineering units display	-	x	-	
	YN	1 to 6	Analog current output register Y 1	Engineering units display	%	x	-	
	HI	1, 2	Analog voltage output registers Y 2, 3	Engineering units display	%	x	-	
			Auxiliary output registers Y 4, 5, 6	Engineering units display	%	x	-	
			Control module PV/SV engineering units display 100% value	-9999 to 9999	-	O	1000	
LO	1, 2	Control module PV/SV engineering units display 0% value	-9999 to 9999	-	O	0		
DP	1, 2	Control module PV/SV engineering units display decimal point position	1 to 4	-	O	3		
DI	DI	1 to 6	Status input	0/1	-	x	-	
	DO	1 to 16	Status output and internal status	0/1	-	x	-	
	MODE	MODE	1 to 5	Operation mode	See Table 5-1-2	-	O	0
CHECK ALARM	CHECK ALARM		Self-diagnosis: code displaying cause of fault	Refer to Section 5-6				
	ALARM		Process alarm: code displaying cause of alarm					
	STALM		STC alarm: code displaying cause of alarm					
N	↑		Item numbers change (The type number (N) is changed)	-	-	-	-	
▲			Data increase setting	-	-	-	-	
⊞			Increasing the setting speed (▲ or ▼ are pressed simultaneously with ⊞)	-	-	-	-	
▼			Data decrease setting	-	-	-	-	

Note 1: PXN and PYN are effective for SLPC-□51 and SLPC-□81.

Note 2: STC and STC parameters are effective only for SLPC-□81.

Note 3: Action range is 2 to 9999 sec. (0 & 1: OFF)

Table 5-1-2. Control Modes (MODE).

MODE	Set point	Set conditions	Default value		
1 (Recovery from power failure)	0	COLD start. The controller is restarted in manual mode, and manipulated output restarts from -6.3%.	0		
	1	HOT start. The controller is restarted in exactly the same mode and status it was in immediately before the power failure.			
2 (<input type="checkbox"/> mode)	0	<input type="checkbox"/> mode canceled; the setpoint is set with the front-panel SET key, without remote setting.	0		
	1	In <input type="checkbox"/> mode, the data stored in A1 register is set as a setpoint.			
	2	In <input type="checkbox"/> mode, the data transmitted from a supervisory system is set as a setpoint.			
3 (Control element 2 setting)	CSC	0	Set when using CSC or SSC.	0	
		1			Cascade open; the output signal of the first loop is adjusted with tuning panel pushbutton switches (SV2).
	SSC	0			External second loop setting; the data stored in register A5 is set as a setpoint for the second loop.
		1			Second loop instrument setting; the setpoint of the second loop is adjusted with tuning panel pushbutton switches (SV2).
4 (Supervisory system backup)	0	When the supervisory system (*1) fails, operation mode is switched to manual (M) to enable controller output to be manipulated manually.	Set when performing communications with a supervisory system.	0	
	1	When the supervisory system (*1) fails, the setpoint is held in auto (A) mode for automatic control.			
5 (Supervisory setting)	0	Setting/operation by a supervisory equipment (*2) is enabled.	Set when performing communications with a supervisory system.	0	
	1	Setting/operation by a supervisory equipment (*2) is inhibited.			

*1 Supervisory system: System, with which the computer or Operator station is connected.

*2 Supervisory equipment: Computer, CENTUM, YEWPACK or μ XL Operator station.

(3) TUNING switch

Enables or inhibits the functions of the TUNING pushbutton switches (, ,).

ENABLE: Settings and resettings are enabled.

INHIBIT: Settings and resettings are disabled.

(4) ACTION switches

Select the direction of control action between direct (DIR) and reverse (RVS).

DIR1/RVS1: Set the action of the basic control module or the first control element (CNT1) of the cascade or signal selector control module.

DIR2/RVS2: Set the action of the second control element (CNT2) of the cascade or signal selector control module.

DIR (direct action): Deviation = Process variable - Setpoint

RVS (reverse action): Deviation = Setpoint - Process Variable

(5) ROM socket

Used to install the ROM containing the user program. The ROM can be secured in position by turning the socket-lock clockwise. Turn the socket-lock counterclockwise to dismount the ROM.

(6) CONNECTOR (PROGRAMMER)

Used to connect the cable of an SPRG programmer.

Keyboard operation (See Figure 5-1-6.)

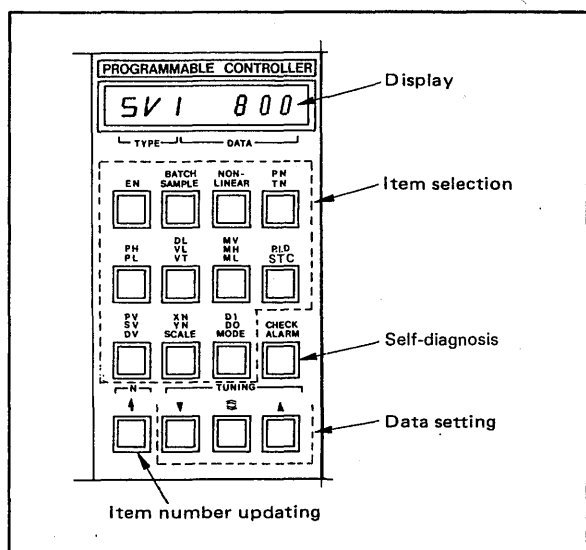

Figure 5-1-6. Keyboard Functions.

(1) Item (TYPE) selection

Press the key of a desired display item, and the data type code (TYPE) for that item will be displayed, along with its value (DATA). If more than one item has been assigned to a single key, the display changes from one item to another each time the key is pressed.

(Example of key operation and display)

- ① PV/SV/DV key. Each arrow mark indicates one key operation.

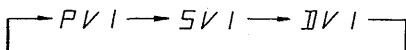

- ② NONLINEAR key. Each arrow mark indicates one key operation.

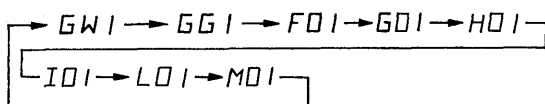

(2) Item number updating

The item number can be updated (increased) by pressing the N key.

(Example of key operation and display)

XN key. Each arrow mark indicates one key operation.

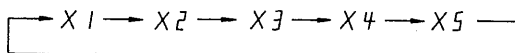

(3) Data updating

The data value can be increased or decreased by pressing the TUNING keys (▲, ▽, ⊞).

These keys are operative only when the TUNING slide switch is set to the ENABLE position.

- ▲ : Increase data value.
- ⊞ : Increase/decrease data value fast. (Press concurrently with ▲ or ▼.)
- ▼ : Decrease data value.

(4) Self-diagnostics

The operating status of the controller can be displayed and checked by pressing the CHECK ALARM key. The method of display is identical with (1). See Section 5-7 for further details.

(5) Display turn-off

The display goes off automatically approximately 30 minutes after the last key operation. This eliminates unnecessary current consumption. The display lights up again when key operation is resumed.

Unused signals and parameters

Input/output signals and parameters that are not used in the application program can also be "displayed" or "set" by keyboard operations; such data, however, is irrelevant to, and has no effect on, the execution of control and computational functions.

5-2. Preparations for Operation.

Make preparations with the controller installed in the panel, or removed and placed on a work table. (The controller is assumed to be in housing.)

Removing the internal assembly from the housing:

- (1) Pull out the internal assembly by pushing up the stopper located below the front panel. When it is drawn out halfway, the internal assembly is restrained by an intermediate stopper. The tuning panel is fully operative at this stage. (See Figure 5-2-1.)

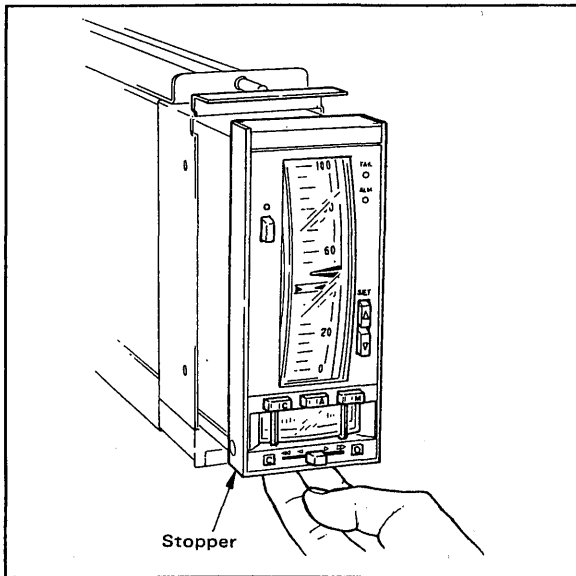

Figure 5-2-1. Pulling Out Internal Assembly.

- (2) To remove the internal assembly from the housing, push down the intermediate stopper spring while pulling the assembly out from the housing as shown in Figure 5-2-2.

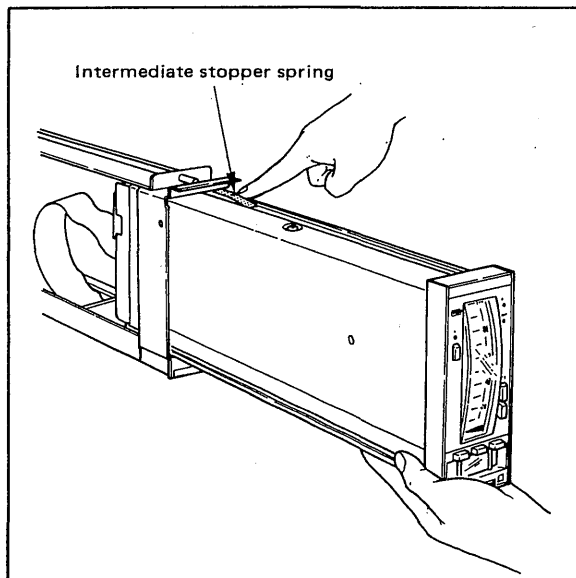

Figure 5-2-2. Removing Internal Assembly.

- (3) To separate the internal assembly from the housing, detach the connector from the assembly. (See Figure 5-2-3.)

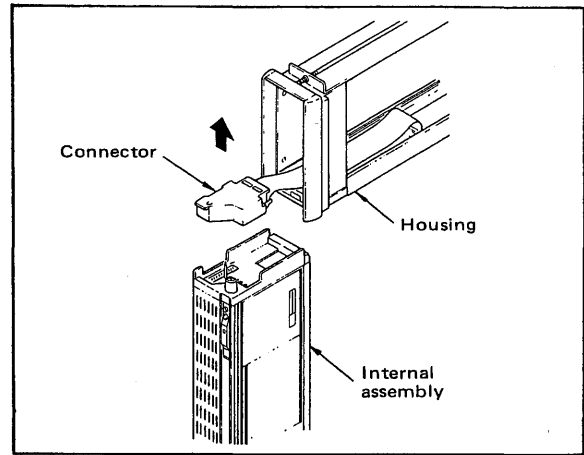

Figure 5-2-3. Detaching Connector.

5-2-1. Checking Special Parts Are Installed.

Check to see that the fuse, data-protect battery, and applications ROM are installed in the proper positions.

If any of them has not been installed, see Section 6-3, "Parts Replacement", for installation procedures.

5-2-2. Preparations for Operation.

- (1) Setting valve open/closed indexes (See Figure 5-2-4.)

Position the valve open/closed marks to agree with the control valve action (direct or reverse).

The open/closed marks can be removed manually or by using a pair of tweezers.

C : Closed (valve closing direction)

O : Open (valve opening direction)

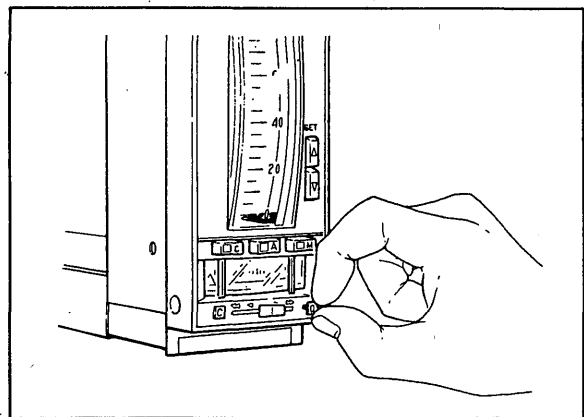

Figure 5-2-4. Setting Valve Open/Closed Indexes.

(2) Setting the tuning board (See Figure 5-2-5.)

Set the DIR/RIV select switch on the tuning panel to the required position.

Next, turn on the power, and set the TUNING switch to ENABLE. Parameters can now be set from the keyboard.

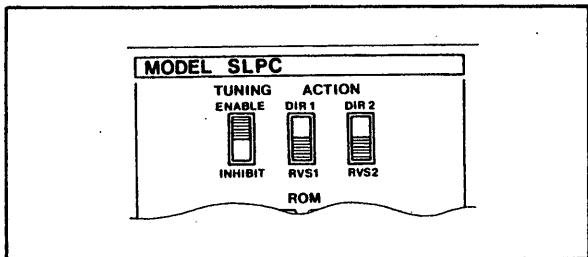

Figure 5-2-5. Setting Select Switches.

(3) Mode Setting

Call up the display MODE with a key operation, and set the desired mode by pressing ▲ or ▼.

(Display and setting example)

Key-in sequence	Display	Description
MODE	MODE1 0	
▲	MODE1 1	If 0 is acceptable, proceed to the next step.
↑	MODE2 1	
▼	MODE2 0	If 1 is acceptable, proceed to the next step.
↑	MODE3 0	
⋮	⋮	

Note: ▲ and ▼ take about 1 second for activation. (This time is required to prevent faulty mode setting.)

(4) Scale Setting

Set the scale — for indicating the process variable and setpoint in engineering units — in this order: maximum value, minimum value, and decimal point.

Maximum value (HI1): Set the value to be displayed when the internal data is 1.0. Key in an assigned 4-digit integer.

Minimum value (LO1): Set the value to be displayed when the internal data is 0.0. Key in an assigned 4-digit integer.

Decimal point (DP1): Specify the decimal point position by its number.

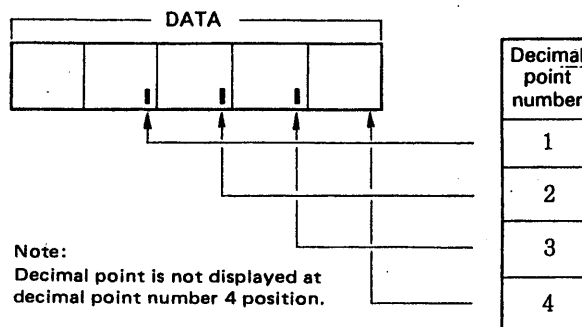

Note: Decimal point is not displayed at decimal point number 4 position.

(Example) Setting a scale range of -10.00 to 40.00

Key-in sequence	Display	Description
SCALE	HI1 1000 LTYPE LDATA	Current HI1 value is displayed in the DATA section.
▲	HI1 4000	may be used concurrently.
SCALE	LO1 0 LTYPE LDATA	Current LO1 value is displayed in the DATA section.
▼	LO1-1000	may be used concurrently.
SCALE	DP1 3	Current DP value is displayed in the DATA section.
▼	DP1 2	For details of decimal point, see the figure above. However, use the ▲, ▼ keys to change a setting.
SCALE	HI1	X1→Y1→HI1 For cascade or selector control, the scale for the second control element must be set in the same way as for the first control element.
↑	HI2	
SCALE	LO2	
SCALE	DP2	

(5) Setting other parameters

Set all other parameters necessary for control and computation. Parameter-setting can be facilitated by the use of data sheets. Table 5-1-1 lists the parameters and their setting ranges.

(Parameter-setting example)

Setting the integral time for the second control element to 600 seconds:

Key-in sequence	Display	Description
T1	TI1	
↑	TI2 1000	Current TI2 value is displayed.
▼	TI2 600	may be used concurrently.

Other parameters can also be set in the following sequence:

- ① Item selection: Select a desired item using one of the 11 item (type) keys.
- ② Number updating: Update the item number with the ↑ key.
- ③ Data setting: Set the data value with the ▼, ⊞, and ▲ keys.

(6) Initial value, default value

Initial values can be loaded into ROM at the same time the user program is entered by using an SPRG Programmer.

If any data that was set from the keyboard is lost due to a power supply failure coupled with the lack of a data-protect battery, its initial value stored in ROM is automatically loaded by CPU as a setting data and the control starts.

Default values are the values when the programmer and the parameter are initialized while connected with the SPRG. When you create a new user program, be sure to initialize the programmer and the parameter. (See Tables 5-1-1 and 5-1-2.)

See Table 5-4-1 for STC parameters. Set the parameters again if necessary.

(7) Inclined mounting

When controller is mounted at an angle to the vertical, the indicator requires a zero adjustment. See Section 6-2 for the zero adjustment procedures.

When all preparations are completed, disconnect the power plug from the controller, install it in the panel, connect I/O signal lines, and finally apply power.

5-3. Start-Up and Operation.

NOTE

This section explains the procedures for start-up and operation of the controller.

The procedures for start-up and operation of the controller may vary with the computation and control programs used. The example below illustrates simple PID control.

The reader should fully understand the procedures described below before proceeding with controller startup and operation.

5-3-1. Manual Start-up.

(1) Manual operation with the manual operation lever

- a. Press the **M** mode transfer switch. (Its built-in indicator lamp comes on.) (See Figure 5-3-1.)

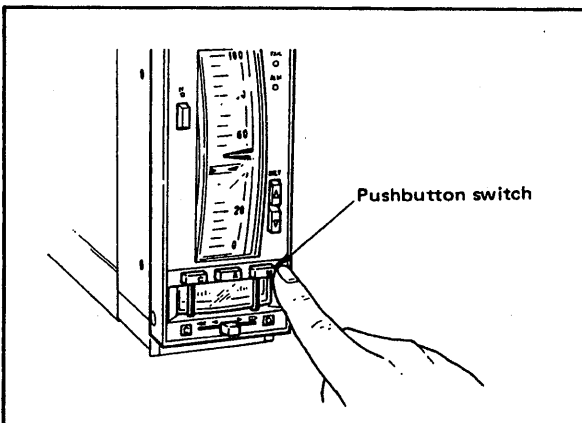

Figure 5-3-1. Selecting Manual Mode.

- b. Adjust the manipulated output signal by moving manual operation lever to the left or right. (See Figure 5-3-2.)

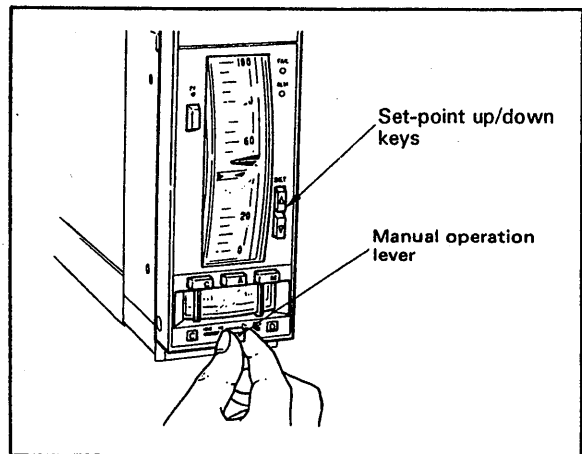

Figure 5-3-2. Manual Output Operation.

- c. Set a desired setpoint by using the set-point up/down keys. (See Figure 5-3-2.)

5-3-2. Alarm Checking and Transfer to Auto Mode.

Assume that smooth response characteristics have been achieved through manual output operation and the process variable has reached a state of equilibrium at or in the vicinity of the setpoint.

(1) Alarm checking (See Figure 5-3-3.)

When the front-panel ALM lamp is on, it indicates that some signal line error has been encountered. Determine the cause of the error by calling the CHECK/ALARM item on the tuning panel and remove it.

When the FAIL lamp is on, it indicates that a failure has occurred in the SLPC programmable indicating controller itself. (See Section 5-5.)

(2) Transfer from manual operation to automatic operation

Press the **A** mode transfer switch, and the built-in indicator lamp comes on to indicate auto mode is established. Mode transfers require no balancing operation, as they occur bumplessly.

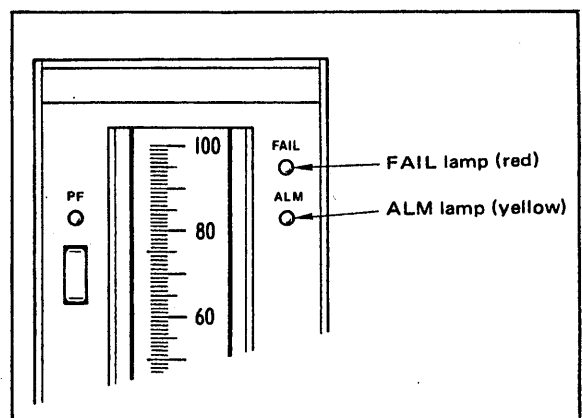

Figure 5-3-3. FAIL and ALM Lamps.

5-3-3. Normal Operation.

(1) Operation mode transfer

The SLPC programmable indicating controller can be switched from one mode to another by simply pressing the **C**, **A**, or **M** mode transfer push-button switches provided that direct transition from **M** to **C** mode is prohibited. Mode transfers require no balancing operation, as they occur bumplessly.

(2) Parameter setting on the tuning panel

Controller parameters can be set or reset at the user's discretion by simply pulling the internal assembly out from its housing and entering the parameters on the tuning panel. After parameter setting, set the TUNING slide switch to the INHIBIT position to prevent accidental changes to the parameters.

5-4. Setting and Display of Self-Tuning Function.

The self-tuning function of the SLPC-□81 automatically adjusts P, I and D parameters to their optimum values depending on the characteristics of the controlled system.

5-4-1. Self-Tuning Parameters.

Table 5-4-1 lists the setting parameters which are related to the self-tuning function. These parameters are assigned to the **PID/STC** key on the tuning panel.

(1) STC (Setting STC mode)

STC mode is set as follows:

OFF	The STC action is stopped.
0	New PID values are displayed. (PID values are not automatically updated.)
1	STC ON. PID values are automatically updated.
2	Automatic start-up. (Refer to Paragraph 5-4-2.)
0, 1	On-demand tuning. (Refer to Paragraph 5-4-3.)

For setting the STC mode, use the ▼ and ▲ keys on the tuning panel as shown below. Note that STC = 2 can be set only in MAN mode.

▲ key: OFF → 0 → 1 → 2
 ▼ key: 2 → 1 → 0 → OFF

(2) PB, TI, TD (PID parameters)

These PID parameters are used in control computations. When self-tuning action status at STC = 1, the initial setting automatically updates these values.

Table 5-4-1. Names and Descriptions of Self-Tuning Parameters.

Type	Number (N)	Name/description	Display/setting range	Unit	Parameter values when each event is occurred				Date setting (Note 2)			
					Factory default values for/NPR	Parameter initialization with SPRG programmer (Note 4)	*E ROM RAM volatilization (Note 5) (Note 8)	*A ROM RAM volatilization (Note 6) (Note 8)	OFF	0	1	2
STC	-	STC mode	OFF, 0, 1, 2	-	OFF	No change	0	0	○	○	○	-
PB	1, 2	Proportional band	6.3 to 999.9	%	999.9	999.9	ROM initial value	ROM initial value	○	○	○	-
TI	1, 2	Integral time	1 to 9999	sec	1000	1000	ROM initial value	ROM initial value	○	○	○	-
TD	1, 2	Derivative time	0 to 9999 (Note 3)	sec	0	0	ROM initial value	ROM initial value	○	○	○	○
IP	1, 2	Process type	0, 1	-	0	No change	0	0	-	○	○	-
TR	1, 2	Process response time	4 to 9999	sec	300	300	ROM initial value	300	-	○	○	-
NB	1, 2	Noise band	Engineering unit equivalent to 0 to 20% of the value set in SCALE	-	0.0	No change	0.0	0.0	-	○	○	-
OS	1, 2	Desired response pattern type	0, 1, 2, 3	-	2	2	ROM initial value	2	-	○	○	○
MI	1, 2	MV. applied signal amplitude	0.0 to 20.0	%	5.0	No change	5.0	5.0	-	△	△	○
R (Note 1)	01, 06	P.B. high-limit value	6.3 to 999.9	%	999.9	999.9	ROM initial value	999.9	-	○	○	-
	02, 07	P.B. low-limit value	6.3 to 999.9	%	6.3	6.3	ROM initial value	6.3	-	○	○	-
	03, 08	Integral time high-limit value	1 to 9999	sec	9999	9999	ROM initial value	9999	-	○	○	-
	04, 09	Integral time low-limit value	1 to 9999	sec	1	1	ROM initial value	1	-	○	○	-
	05, 10	Derivative time high-limit value	0 to 9999	sec	2000	2000	ROM initial value	2000	-	○	○	-
PA	1, 2	New P.B. calculated value	6.3 to 999.9	%	999.9	No change	PBn value	PBn value	/	/	/	/
IA	1, 2	New Integral-time calculated value	1 to 9999	sec	1000	No change	TIn value	TIn value	/	/	/	/
DA	1, 2	New derivative-time calculated value	0 to 9999	sec	0	No change	TDn value	TDn value	/	/	/	/
CR	1, 2	Probable error	0.00 to 99.99	-	0.00	No change	0.00	0.00	/	/	/	/
RT	1, 2	Distributed signal ratio	0.000 to 9.999	-	0.000	No change	0.000	0.000	/	/	/	/
LM	1, 2	Equivalent dead-time	0 to 9999	sec	0	No change	0	0	/	/	/	/
TM	1, 2	Equivalent time constant	0 to 9999	sec	0	No change	0	0	/	/	/	/
GM	1, 2	Equivalent process gain	0.000 to 9.999	-	0.000	No change	0.000	0.000	/	/	/	/

Note 1: R01 to R05 are limit values for PB1, TI1 and TD1. R06 to R10 are limit values for PB2, TI2 and TD2.

Note 2: ○ : Setting is required.
 - : Setting is not required.
 / : For display only
 △ : In on-demand mode

Note 3: Action range is 2 to 9999 sec. (0 & 1:OFF)

Note 4: Set PBn, TIn, TDn, TRn, OSn and R01 to R10 again. (n=1, 2)

Note 5: Set STC, IPn, NBn, MIn again. (n=1, 2)

Note 6: Set STC, IPn, TRn, NBn, OSn, MIn and R01 to R10 again. (n=1, 2)

Note 7: The ROM initial value is a value when the program is written in user ROM while connected with the SPRG.

Note 8: The user ROM using the function extended by SLPC'E is called '*E ROM.' The other user ROM is called '*A ROM.' (For details, refer to TI 1B4C2-02E.)

(3) IP (Process Type)

This specifies whether the process is static-controlled or integral-controlled. In an integral-controlled process, when step input is applied, the measured value is increased or decreased infinitely. Processes excluding the level control process are almost all static-controlled.

(4) TR (Process 95%-response time)

This specifies a 95%-response time to a step input in the process. STC controllers calculate the desired sampling time as well as time required to observe a measured signal waveform.

Set an appropriate TR in the following ways:

- ① Estimate the TR from the step-response waveform of the process.

Set the TR to the time required for a process variable change (ΔPV) until it reaches 95% of the settling value. If the response time can be approximated with dead-time L and first-order-lag time constant T , $TR = L + 3T$.

- ② When the process is integral-controlled:

When a pulse input is applied, set the TR to the time required for a process variable change (ΔPV) until it reaches 95% of the settling time.

- ③ Estimate from the continuous operating conditions

Read the attenuation wave cycles T_p that are considered normal, and set $TR = T_p$.

- ④ When response time variations are estimated: Select the desired response time. When the response time between an increase and a decrease in the measured temperature for furnace temperature measurements differs, for example, select whichever response time is greater.

- ⑤ Notice:

$1/20$ of the TR is the sampling period T_s for estimating the process, so a response waveform less than $2T_s$ cannot be captured correctly.

Generally, when the TR is larger than the correct TR value, it has fewer process-characteristic errors. If the TR changes, data files are initialized during a response time of $4TR$, so the STC does not operate.

(5) NB (Noise Band)

Set the NB to twice the peak value of the noise signal superimposed on the measured signal. The NB is used to prevent the process from being influenced by a noise signal.

(6) OS (desired response pattern)

Set the type of desired response pattern (a criteria for self-tuning).

0	Overshoot zero
1	Overshoot about 5%
2	Overshoot about 10%
3	Overshoot about 15%

(7) MI (Signal applied to the MV)

When the STC is set to mode 2 or the on-demand mode, set an additional signal that is applied to the manipulated variable (MV) so that the measured value overshoots by about 5% of the full-scale. When the STC is in mode 2, it is operating manually. Therefore, apply the MI so that the current controlled deviation is maintained. When the STC is in the on-demand mode, it is in automatic operation. Therefore, apply the MI so that the controlled deviation decreases.

(8) R01 to R10 (P, I, D limit values)

These parameters can be used to limit the adjustable ranges of P, I and D parameters. If "high limit value \leq low limit value" is set, the parameter concerned is fixed at the low limit value.

(9) PA, IA, DA (new calculated P, I, D values)

If $STC = 0$ (for display only of calculated P, I and D values), the "optimum" parameter values calculated by the STC functions can be displayed, but are not used in control computation. When $STC = OFF$ or 1, displaying PA, IA and DA values results in the same values as for PB, TI and TD, respectively.

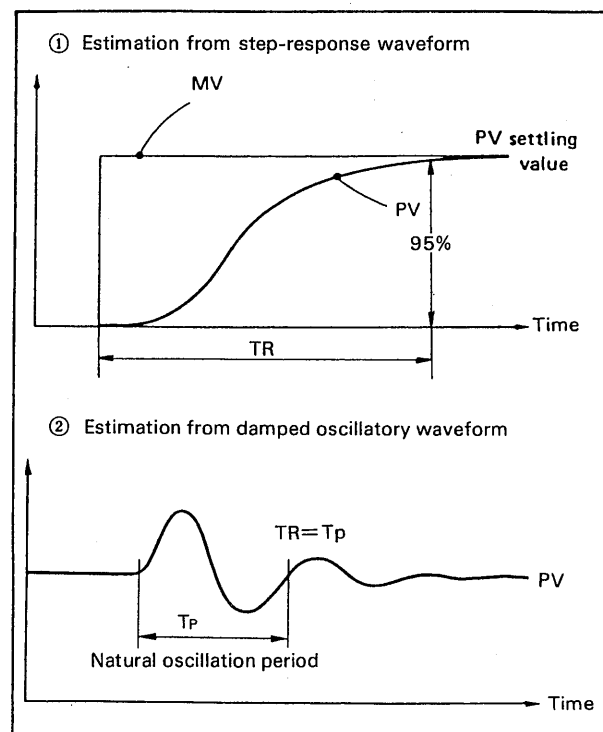

Figure 5-4-1. Method of Estimating TR.

(10) CR (Probable Error)

An error when process characteristics are estimated. The STD controller requires PID parameter settings when the CR is less than 5%.

(11) RT (Signal Distribution Ratio)

This indicates the ratio of the PV distributed value to the model distributed value. STC controllers calculate a signal distribution ratio using a final model (STC 1 for the STC mode set to 0) to find process-characteristic variations. When the distributed value of the process signal matches that of the model output signal, RT is about 1. When RT is greater than or equal to 2 or when it is less than or equal to 0.5, an alarm occurs.

(12) LM, TM, GM (Equivalent model)

STC controllers indicate a simulated process model with an approximation of the dead-time and first-order-lag system. LM, TM and GM indicate equivalent dead-time, the equivalent first-order-lag time constant, and equivalent gain, respectively. For LM, TM and GM, respective values when the STC mode is 1 and when the CR is 5% or less are retained. Calculated PID parameters are related to PB, TI and TD.

The CR is updated by the process characteristics. When the CR is greater than 5%, LM, TM and GM are not updated.

5-4-2. Automatic Startup.

STC mode is set to 2 for automatic start-up mode. In this status, the STC parameters (PB, TI, TD, IP, TR, NB, R) are automatically calculated by the step-response method.

(1) Applicable control modules

BSC Basic control module

CSC Cascade control module

Available for the Secondary loop with cascade open

Available for the Primary loop when cascade closed

(2) Setting parameters

STC, OS and, if required, TD are set.

Set TD = 0 for PI control.

TD is set to 1 or greater for PID control.

(Automatic start may result in PI control.)

(3) Operation procedure

- ① First make sure that no STALM (Refer to Paragraph 5-7-6) has occurred.
- ② In MAN mode, set STC to 2.
- ③ Manually stabilize the process variable signal to an appropriate value.
- ④ Switch the control mode to AUTO or CAS (automatic start-up begins).

The A or C lamp on the front of the instrument blinks.

In automatic start-up mode, PID control does not start for 30 seconds, but the controller automatically applies a step change (MI%) to

the manipulated output in the safe direction (to increase the deviation rather than reverse its sign).

The controller calculates the self-tuning parameters from the process response to this step change.

When an STALM has occurred, the control mode may fail to switch to AUTO (CAS). (Refer to Paragraph 5-7-6.)

- ⑤ When the process variable signal stabilizes, the controller automatically returns the manipulated output to its initial value.
 - ⑥ When all of the parameter settings are complete, STC mode is automatically switched from 2 to 1, and PID control starts. The A to C lamp then changes from blinking status to ON.
- (4) Check items in conducting the automatic start-up
- ① The process must be such that a 5% output change will have no undesirable effects.
 - ② If process gain is high, and the process variable changes by more than 1.5MI%, the manipulated output is automatically returned to its initial value.
 - ③ If process gain is low, and the change in the process variable is less than 2%, automatic start-up is considered inappropriate, and after the maximum observation time (about 80 minutes) has passed, the operation mode switches to MAN and an STC alarm is issued.
 - ④ The PID limit values (R01 to R10) are automatically set to four times (for high limit values) or 1/4 (for low limit values) of the initial PB, TI and TD values obtained by automatic start-up.
 - ⑤ If a power failure occurs during automatic start-up, the operation mode is transferred to MAN mode with STC = 0 after the power recovers.
 - ⑥ If a STALM (Refer to Paragraph 5-7-6.) occurs during automatic start-up, the start-up operation is stopped and operation mode is transferred to MAN with STC = 0.
 - ⑦ If, during automatic start-up (with the A or C lamp blinking), the operation mode is switched to MAN, automatic start-up is stopped (STC is set to 0).

5-4-3. On-Demand Tuning

In the on-demand mode, an STC controller allows the operator to carry out self-tuning from the PV response by applying a test signal to the MV value as required.

(1) Applicable conditions

An on-demand tuning operation is possible when the following conditions are all satisfied:

- When only basic control BSC or cascade control CSC is selected. (When selector control

SSC is selected, on-demand tuning is not available.)

- When the control operation is in the AUTO or CASCADE mode. (When the DDC or SPC mode is selected, on-demand tuning is not available.)
 - When the STC mode is set to 0 or 1.
- (2) Setting parameters and operation
- Set parameters when the STC is set to 0 or 1.
 - MI: Sets the amplitude of an applied test signal. Set a value that overshoots by about 5% of the PV. The MI is added to the MV value so that the controlled deviation decreases depending on the DIR/REV switch position and the current controlled deviation. For an integral-controlled process, a pulse signal with an amplitude of TR/5 is added.
- (3) Operation procedures
- a. Check that MI values are correct.
 - b. Check that the STC mode is set to 0 or 1.
 - c. Press the [N] key once and check that the tuning request ("RQ") comes up.
 - d. Then press the [N] key again. If the tuning request is canceled, press any key.
 - e. Thus, the MI is added to the MV. "RQ" will blink for about TR/5 seconds. While "RQ" is blinking, the [N] key, even if pressed, is omitted.

5-4-4. Display of Self-Tuning Operation.

(1) Side tuning panel

When STC = 0 or 1 and the self-tuning function is operating, "0" or "1" blinks. When STC = 2 and start-up is being executed, "2" blinks. When either operation is stopped, or the controller is in MAN mode, the lamp on the tuning panel is lit continuously (not blinking).

- (2) C, A, M mode display lamps (front of instrument)
- While STC = 2 and during start-up, the C or A lamp blinks.

5-5. Setting and Display of Adjustable Set-Point Filter Function.

The adjustable set-point filter (abbreviated as SVF) is based on a PI-D type control algorithm and is configured so that filtering is added to the set-point part. The effect of the filter can be adjusted by two parameters to continuously change the set-point follow-up characteristics between PI-D and I-PD.

SLPC-□51 and SLPC-□81 are equipped with this function.

5-5-1. Effect of Changing the Filter Parameters.

Figure 5-5-1 shows examples of set-point follow-up waveforms observed when parameters PX (α) and PY (β) are separately changed from 0 to 1.

The PX parameter has the greater effect on the follow-up waveform. The larger the value of PX, the faster the rise time of the follow-up waveform. The PY parameter, on the other hand, has a fine adjustment effect — and the larger the value of PY, the smaller the overshoot.

5-5-2. Method for Tuning PX and PY.

(1) When no self-tuning is provided:

- ① Make a step change in the manipulated variable output, and calculate optimum P, I and D values from the response.
- ② Make a step change in the set point, and adjust PX so that the intended followup characteristic is obtained. When derivative action is provided, fine adjustment by PY is possible.
- ③ The recommended values of PX and PY are PX = 0.5 and PY = 0.0.

(2) When self-tuning is provided:

- ① After setting PX = 0.5 and PY = 0.0 (recommended values), start operation using the self-tuning function. PX is optimized to provide the best response to set-point changes; PID parameters are optimized to provide the best response to an external disturbance.

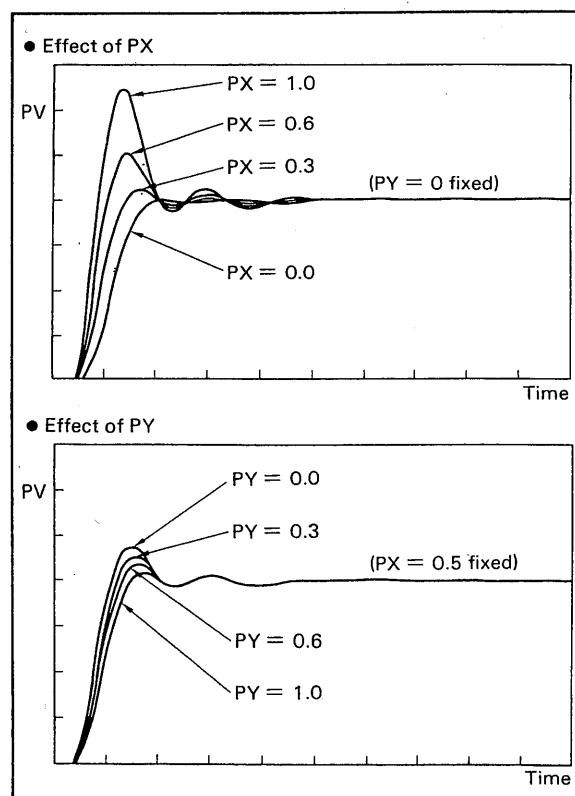

Figure 5-5-1. Effects of PX and PY Parameters.

5-6. Automatic Control.

When applying the controller to an unknown process, it is useful to examine the performance of the process in manual mode.

This can be useful in estimating the proportional band, integral time and derivative time required for automatic mode.

For example, if a small change in the controller output causes a large fluctuation in the process variable value, the width of the proportional band must be increased (the gain must be reduced) to assure stability. Conversely, the proportional band must be narrowed.

For a process which responds quickly to a change in the controller output, the integral and derivative time constants must be short. Conversely, for a process having a long recovery time, the integral and derivative time constants must be long.

(1) "Proportional + integral" controller

a. Set the operation mode to **M**, and manually adjust the process variable until it agrees with the set point. Set the integral time to 9999 seconds, set the proportional band to a sufficiently large value, and then set the derivative time to 0 seconds.

b. Set the operation mode to **A**.

c. Perform the following operations to obtain the optimum value for the proportional band.

Lower the proportional band in steps from a sufficiently large value (for example, 100% → 50% → 20%). Take a sufficiently long time for each step, so that the control state can be fully observed. Continue this operation until the control loop begins cycling. (Cycling refers to periodic oscillation of the process variable pointer around the set point. This phenomenon is caused by setting the proportional band narrower (setting the gain higher) than the optimum value for the process.) The optimum proportional band is approx. 2.2 times that of the proportional band which causes such cycling. Next measure the cycling period. The optimum integral time can be obtained by multiplying this oscillation period by 0.83.

Up to a point, decreasing the integral time improves the control response. But, if the integral time is decreased past a limit, which is decided by the lag characteristic of the process, cycling will start. If this happens, increase the integral time gradually until the cycling stops.

(2) "Proportional + integral + derivative" controller

a. Set the operation mode to **M**, and manually adjust the process variable until it agrees with the set point. Set the integral time to 9999 seconds. Set the proportional band to a sufficiently wide value, and set the derivative time to 0 seconds.

b. Set the operation mode to **A**.

c. Change the proportional band as described above, and find the point where cycling just starts to occur. Measure the proportional band value (PBu) at this point and the cycling period (Pu).

d. The optimum settings can be determined as follows:

Proportional band = 1.7 PBu

Integral time = 0.5 Pu

Derivative time = 0.125 Pu

The method explained above is called the Ziegler-Nichols threshold sensitivity method, and provides a response characteristic with approximately 25% amplitude attenuation.

Various adjustment methods — such as the step-response method — have been proposed as alternatives to the Ziegler-Nichols method; please refer to textbooks on automatic control.

5-7. Actions to be Taken When FAIL and ALM Lamps Light Up.

The SLPC programmable indicating controller is furnished with a FAIL lamp and an ALM lamp to visually indicate failures in the controller itself and signal errors, respectively. Whenever a lamp lights up or begins to flash, take appropriate corrective action promptly.

5-7-1. Actions to be Taken when FAIL Lamp Lights Up.

The FAIL lamp, when lit, indicates that a serious failure has occurred in the controller.

- (1) Monitor the current output signal and set it, with the manual operation lever, to a value that does not adversely affect the process.

The measurement indicator gives the value of analog input signal No.1 (X1).

The values just before the failure are held for analog and status outputs during failure. The manual operation lever permits manipulating the current output, but cannot hold the manipulated output constant for a long time (the voltage output signal decreases with time). If the output has to be held, use the SPBD manual control station to back up the SLPC. For either output, an incorrect value may be held depending on which part of the circuit failed.

- (2) Insert the cable connector from the SPBD manual control station into the jack at the bottom of the SLPC housing and switch the controller output from the SLPC to the SPBD. (See Figure 5-7-1.)

- (3) Select the CHECK item on the tuning panel and determine the cause of the failure. (See Section 5-7-4.)

If the failure is considered attributable to a hardware fault, remove the instrument from the panel and troubleshoot it as instructed in Section 7.

5-7-2. Actions to be Taken when ALM Lamp Lights Up.

An illuminated ALM lamp indicates that the controller's high- or low-limit alarm is actuated or the input/output signal line is open. Select the CHECK, ALARM and STALM (SLPC-□ 81 only) items on the tuning panel and examine the cause of the alarm condition. (See Sections 5-7-4 and 5-7-5.)

5-7-3. Actions to be Taken when ALM Lamp Flashes.

The ALM lamp begins flashing when the voltage of the data-protect battery drops. Replace the battery as instructed in Section 6-3-4.

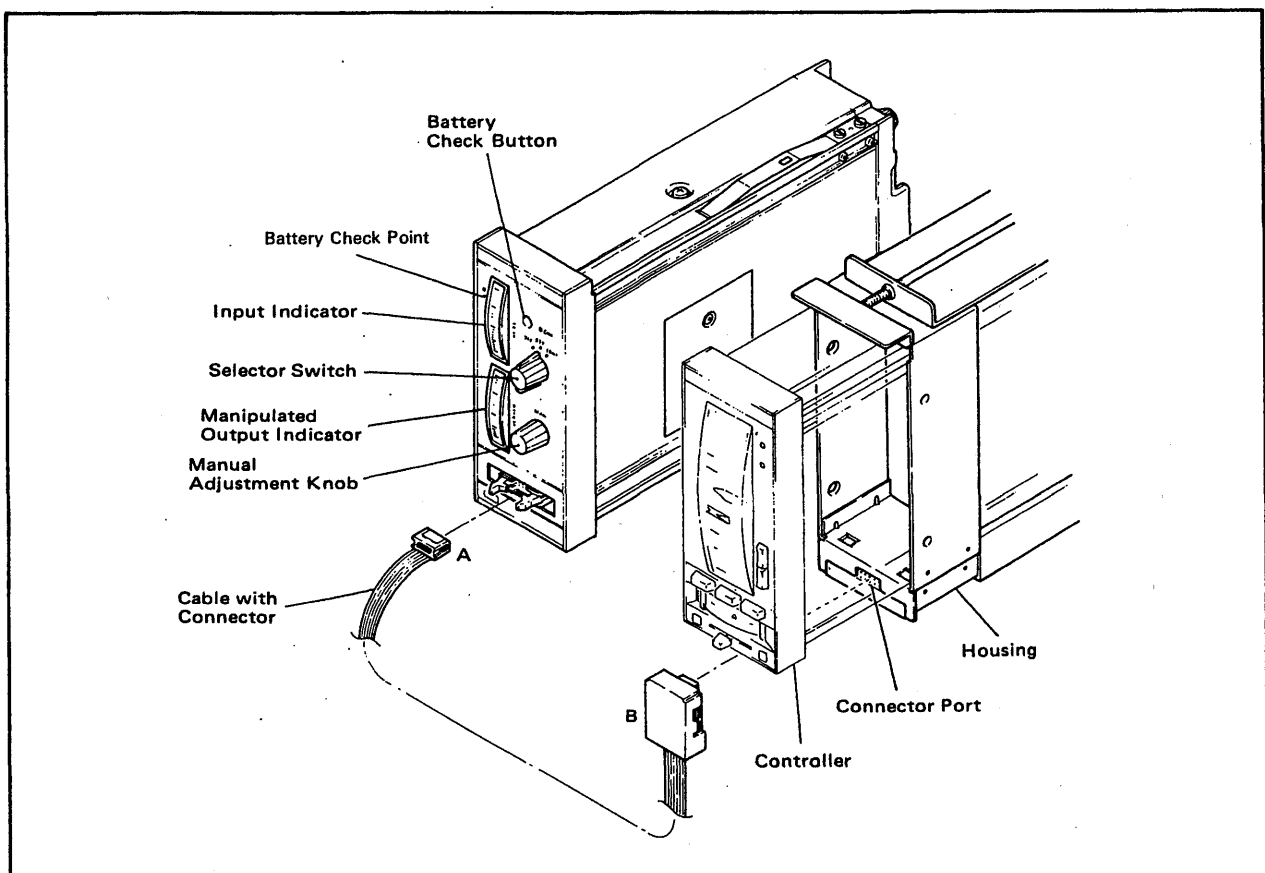

Figure 5-7-1. SPBD Connection.

Notes:

- (1) When the ALM lamp begins flashing during normal operation, replace the battery immediately.
- (2) A flashing ALM lamp overrides a continuously lit alarm lamp. No alarm status can be indicated, therefore, while the ALM lamp is flashing. (Other alarms can still be displayed on the tuning panel.)

5-7-4. CHECK Display.

The CHECK display items are listed below:

Lamp	CHECK display	Diagnosis
—	0 0	Normal.
FAIL	0 1	Fault in A/D converter.
FAIL	0 2	Fault in D/A converter.
ALM	0 4	Arithmetic range overflow.
ALM	0 8	Input signal overrange.
FAIL	1 0	Unmounted or failed User ROM.
ALM	2 0	Data protect battery not installed, or (Lamp flashing) low battery voltage.
ALM	4 0	Current output signal line open or overloaded.
FAIL	8 0	RAM memory data lost*.
ALM	PWR ERR	Supply voltage too low.
FAIL	—	Microprocessor faulty (display not possible).

* A value of 80 in the display together with an illuminated ALM lamp following a power failure (after power application) indicates the occurrence of power failure. When 80 is displayed, check the PID and other parameters on the side panel since they have been initialized. The display of 80 during normal operation indicates a failure due to the loss of internal data.

If two or more faults occur at the same time, the displayed value is the total of the individual display values (sum of their hexadecimal values).

(Examples)

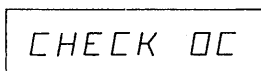

0C = 04 + 08 (Computing range overflow + Input signal overrange)

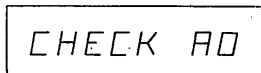

A0 = 20 + 80 (Battery low + Data lost)

The display value returns to 00 upon removing the cause of the fault. The value 80 in the display (internal data lost), does not return to 00 automatically; use the key to reset the display.

5-7-5. ALARM Display.

The alarm status of the control function is displayed as a 2-digit number. The ALM lamp also lights up.

(Display)

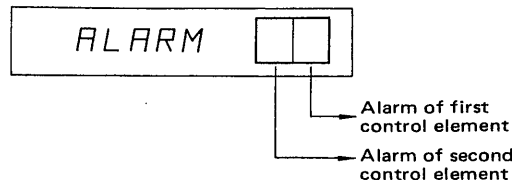

ALARM display	Diagnosis
0	Normal
1	High limit alarm
2	Low limit alarm
4	Deviation alarm
8	Velocity alarm

If two or more alarm conditions occur at the same time, the total of the individual values is displayed (sum of their hexadecimal values).

(Examples)

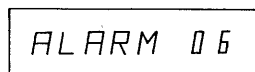

6 = 2 + 4 (Low-limit alarm + Deviation alarm)



E = 2 + 4 + 8 (Low-limit alarm + Deviation alarm + Velocity alarm)

5 = 1 + 4 (High-limit alarm + Deviation alarm)

The display returns to 00 when the alarm conditions are removed.

5-7-6. STALM Display (SLPC-□81 Only).

STALM is assigned to the CHECK
ALARM key and, when the self-tuning function cannot operate normally, displays STALM status using a 2-digit number. Table 5-7-1 shows the diagnoses which correspond to STALM display codes. The ALM lamp also lights up.

When two or more alarms occur simultaneously, the sum of the individual alarm display codes is displayed (i.e., addition of hexadecimal numbers).

Examples:

STALM 06

6 = 2 + 4 (PID values at limits, manipulated variable output stuck at limit)

STALM E0

E0 = 20 + 40 + 80 (STC mode switching, current output open, process variable input over-range)

The display value returns to 0 as soon as the corresponding alarm returns to normal.

Table 5-7-1. Self-Tuning Alarm Display Items.

STALM display	STC mode	Diagnosis	STC action	To clear alarm
00	All	Normal (always 00 when STC = OFF)	Continue	—
01	0, 1	<ul style="list-style-type: none"> ○ There has been an attempt to use a control element whose use in combination with STC is prohibited. ○ Control module is not executed every period. 	Stop	<ul style="list-style-type: none"> ○ Remove cause of alarm(s). ○ Turn STC OFF ○ Press N key
02		<ul style="list-style-type: none"> ○ P, I and D values are at high or low limits. ○ Control samples set in self-tuning functions do not match press conditions (where $RT \geq 2$ or $RT \leq 0.5$). 	Continue	
04		<ul style="list-style-type: none"> ○ Current output open. ○ The manipulated variable output is limited by the output limiter. 	Stop	
		<ul style="list-style-type: none"> ○ The manipulated variable output is limited by the output limiter. 	Continue	
08		<ul style="list-style-type: none"> ○ Process variable input value is out of range. 	Continue	
10	2	<ul style="list-style-type: none"> ○ There has been an attempt to use a control module/element whose use in combination with STC is prohibited. ○ Control module is not executed every period. ○ In CSC mode internal cascade loop was opened or closed. 	<ul style="list-style-type: none"> Transfer to MAN mode, STC = 0. Stop 	<ul style="list-style-type: none"> ○ Rest STC = 2 ○ Turn STC OFF ○ Press N key ○ Must remove cause of alarm
20		<ul style="list-style-type: none"> ○ A command to change the STC mode or turn off STC action was issued by a user program or manually. ○ The operation mode was transferred to BACK UP MAN status. 		
40		<ul style="list-style-type: none"> ○ Power failure. ○ Current output open. ○ There is a possibility that a step change in MV may cause the output value to reach the limit value or MV over range. 		
80		<ul style="list-style-type: none"> ○ Process variable input is out of range. ○ The change in the process variable was too small for automatic start-up to be executed (and the maximum observation time (about 80 minutes) has passed). 		

5-8. Connecting an SPRG Programmer.

Use an SPRG Programmer to change set data or control programs stored in the controller.

Refer to the SPRG Instruction Manual (IM 1B4W1-02E) for detailed SPRG operation information.

This section explains how to connect the SPRG Programmer to the SLPC programmable indicating controller.

CAUTION

Never attach or remove the SPRG connector from the SLPC while power is being supplied.

5-8-1. Connecting the SPRG.

- (1) Turn off both the SLPC and SPRG.
- (2) Set the SPRG in PROGRAM ,pde/
- (3) Attach the SPRG cable connector to the SLPC.
(See Figure 5-8-1.)
- (4) Turn on the SPRG.
- (5) Turn on the SLPC.

5-8-2. Disconnecting the SPRG.

- (1) Set the SPRG in PROGRAM mode.
- (2) Turn off the SLPC.
- (3) Turn off the SPRG.
- (4) Detach the SPRG cable connector from the SLPC.

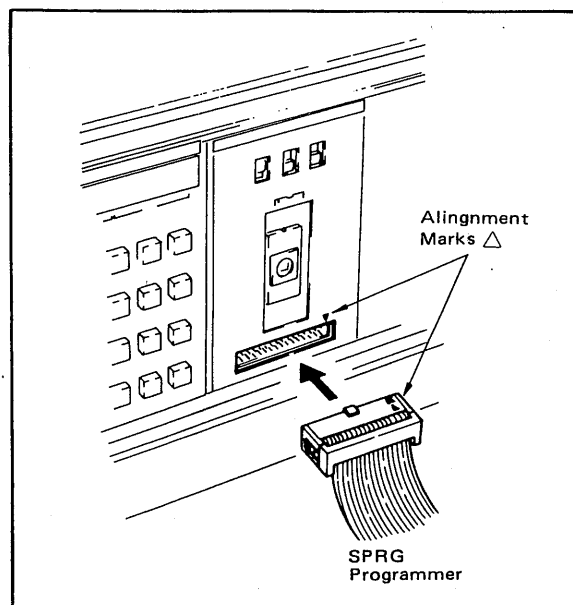

Figure 5-8-1. Connecting the Cable to the SLPC.

6. MAINTENANCE.

This chapter explains the SLPC Programmable Indicating Controller adjustments and parts replacement procedures.

6-1. Test Equipment.

DC voltage/current standard:

Yokogawa Electric Corp. Model 7651

or equivalent 1 unit

SPRG Programmer 1 unit

6-2. Test, Calibration, and Adjustment.

6-2-1. Generating a Maintenance Program.

Connect the SPRG programmer to the SLPC controller, and generate the following program:

(Maintenance program)

Step	Program
01	LD X2
02	ST A1
03	LD X1
04	BSC
05	LD X3
06	ST Y1
07	END

No other operations – such as parameter settings – are required.

After preparing the program, set the SPRG programmer in TEST RUN mode, set MODE2 to 1 on the SLPC controller tuning panel, and press the **C** mode transfer pushbutton switch. Then carry out the following adjustments:

6-2-2. Zero Adjustment of Measurement Indicator (Moving Coil Version).

- (1) Apply a voltage of 3.0 V DC to process variable input terminals XI (terminals 1 (+) and 2 (-)) from the DC voltage/current standard.
- (2) Check that the measurement pointer indicates 50% ±0.5% of the calibration mark on the scale plate.
- (3) If the reading is not in this range, rotate the zero adjustment screw to point to 50%, as shown in Figure 6-2-1.
- (4) Change the input signal to 1.0 V, 2.0 V, 4.0 V, and 5.0 V DC, and check that the readings are at 0%, 25%, 75%, and 100% calibration marks, respectively. The tolerance is ±0.5% of span. Check each calibration mark at the position where the line of sight and set-point value indicator are horizontal.

- (5) If the tolerance is exceeded in (4), apply 3.0 V DC again and make fine adjustments with the reading to fit in the range of 50% ±0.5%.
- (6) Repeat (4) and (5) until the readings at all input points are held within the tolerance.

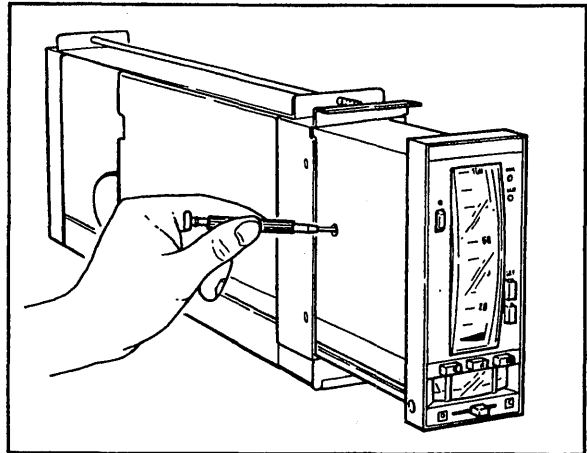

Figure 6-2-1. Zero Adjustment of Measurement Pointer.

6-2-3. Zero Adjustment of Setpoint Index (Moving Coil Version).

- (1) Apply a voltage of 3.0 V DC to input terminals X2 (terminals 3 (+) and 4 (-)) from the DC voltage/current standard.

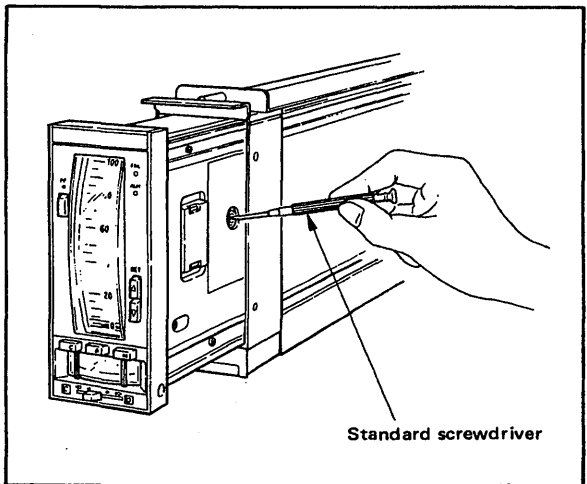

Figure 6-2-2. Zero Adjustment of Setpoint Index.

- (2) Adjust using the same procedure as described in steps (2) through (6) for the measurement pointer zero point (Section 6-2-2). Figure 6-2-2 shows how to adjust the setpoint index zero point.

6-2-4. Adjusting Fluorescent Bar Graph Indicator.

The fluorescent bar graph indicator requires no zero adjustment for either the setpoint index or input indication. Perform only steps (1) and (2), Section 6-2-2.

6-2-5. Zero Adjustment of Output Indicator.

- (1) Apply a standard voltage of 3.0 V to input terminals X3 (terminals 5 (+) and 6 (-) from the DC voltage/current standard. (Keep current output terminals A (+) and B (-) shorted.)
- (2) Make sure that the output index is just on the main scale mark in the middle. The tolerance is $\pm 2.5\%$ (equivalent to 1/2 of each scale division.) (See Figure 6-2-3.)

Check each main scale mark at the position where the line of sight and output indicator pointer are vertical.

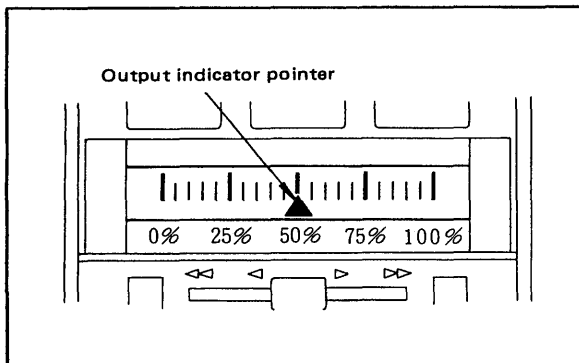

Figure 6-2-3. Output Indicator Main Scale Marks.

- (3) If the index deviates from the tolerance, rotate the zero-adjustment screw so that the index points to the middle main scale graduation. (See Figure 6-2-4.)
- (4) Change the input signal to 1.0 V, 2.0 V, 4.0 V, and 5.0 V DC, and insure that the output index points to the 0%, 25%, 75%, and 100% points accordingly. The tolerance is $\pm 2.5\%$ of span (1/2 of each scale division).
- (5) If the tolerance is exceeded in (4), return to step (1) and make fine adjustments with the reading to fit within the tolerance.
- (6) Repeat steps (4) and (5) as necessary until the readings at all points are held within the tolerance.

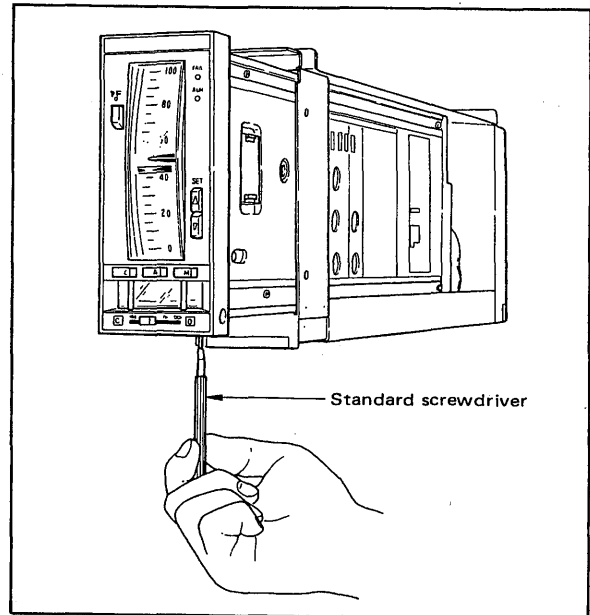

Figure 6-2-4. Zero Adjustment of Output Indicator.

6-2-6. Inclined Mounting.

In the case of an inclined controller, set it up at the actual mounting angle and adjust its measurement pointer and setpoint index zero points as instructed in Sections 6-2-2 and 6-2-3.

6-2-7. Brightness Adjustment of Fluorescent Bar Graph Indicator.

Adjust the brightness of the fluorescent bar graph when it is low. (See Figure 6-2-5.)

Note: Excessive increase in the brightness could have a harmful effect on the fluorescent tube life.

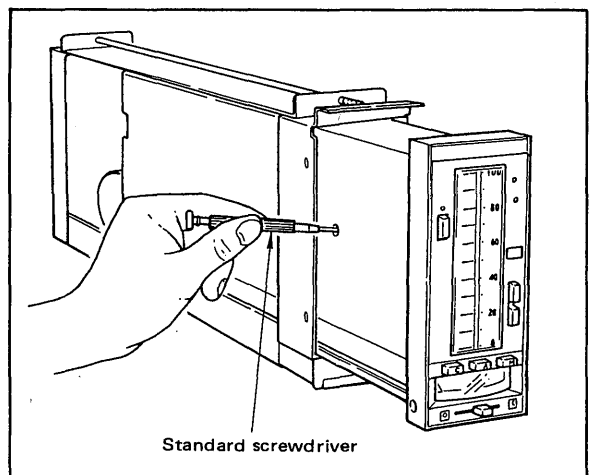

Figure 6-2-5. Brightness Adjustment of Fluorescent Bar Graph Indicator.

6-2-8. Digital Display Setting.

Note: The eight-position DIP switches should be set with your finger nail or small screwdriver.

The fluorescent bar graph version has a four-digit display on the right side of the bar graph indicator on the front panel.

The numeric value displayed on the digital display corresponds with that displayed on the bar graph indicator scale.

When the scale plate is changed, the digital display setting must also be changed by the following procedure.

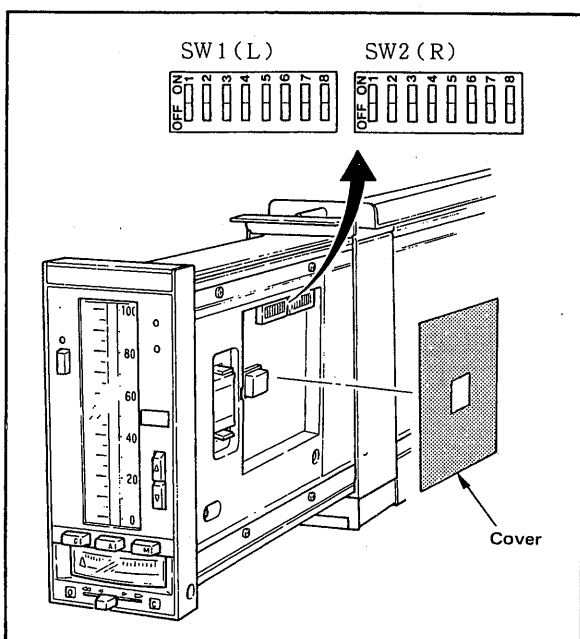

Figure 6-2-6. Eight-Position DIP Switches.

- (1) Remove the cover as shown in Figure 6-2-6.
- (2) Two 8-position DIP switches (L and R) are located side-by-side inside the cover. (See Figure 6-2-6.)
- (3) The DIP switch setting direction marks are printed on the scale plate. (See Figure 6-2-7.)
- (4) Set the DIP switches according to the indicated setting positions so the digital display conforms to the scale graduations on the scale plate.

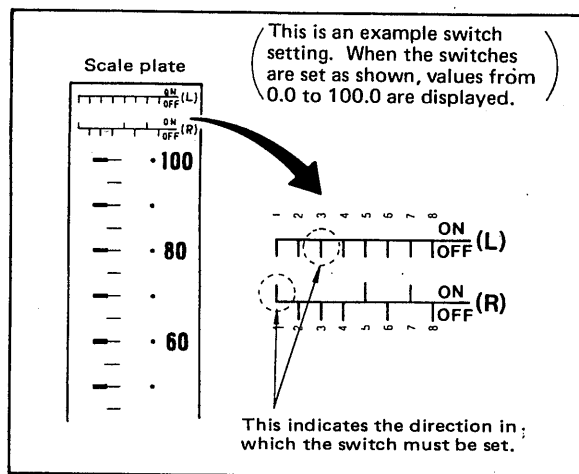

Figure 6-2-7. DIP Switch Setting Direction Marks Printed on Scale Plate.

- (5) If the value displayed on the four-digit display is to be displayed on a different range from the indicator scale range, set the 8-digit DIP switch as follows:

- a. Select the desired display values (minimum and maximum values) from Table 6-1.
- b. Set binary values which correspond to these minimum and maximum values on SW1(L) and SW2 (R). Nos. 1 to 7 of SW1 (L) are used for setting the minimum value, and Nos. 2 to 8 of SW2 (R) are used to set the maximum value.

Notes:

1. Values outside those given in Table 6-1 cannot be displayed.
 2. The display range of the four-digit display unit is -1999 to 4999.
 3. The reading in the four-digit display unit is linear in relation to the input (1 to 5 V DC).
- (6) Decimal Point Position (D.P.) Setting.
- When the four-digit display values include decimal points, a separate decimal-point setting is required in addition to the maximum and minimum value setting described above.

Set No. 8 of SW1 (L) and No. 1 of SW2 (R) as follows depending on the decimal point position required. (See Figure 6-2-8).

Table 6-1. Display Values Given by Digital Display Unit and Corresponding DIP Switch Settings.

Display Value (Minimum or Maximum Value)	DIP Switch Setting	Display Value (Minimum or Maximum Value)	DIP Switch Setting
- 1999	1 1 0 1 1 0 0	1 6 0 0	0 0 1 0 0 0 0
- 1900	1 1 0 1 1 0 1	1 7 0 0	0 0 1 0 0 0 1
- 1800	1 1 0 1 1 1 0	1 8 0 0	0 0 1 0 0 1 0
- 1700	1 1 0 1 1 1 1	1 9 0 0	0 0 1 0 0 1 1
- 1600	1 1 1 0 0 0 0	2 0 0 0	0 0 1 0 1 0 0
- 1500	1 1 1 0 0 0 1	2 1 0 0	0 0 1 0 1 0 1
- 1400	1 1 1 0 0 1 0	2 2 0 0	0 0 1 0 1 1 0
- 1300	1 1 1 0 0 1 1	2 3 0 0	0 0 1 0 1 1 1
- 1200	1 1 1 0 1 0 0	2 4 0 0	0 0 1 1 0 0 0
- 1100	1 1 1 0 1 0 1	2 5 0 0	0 0 1 1 0 0 1
- 1000	1 1 1 0 1 1 0	2 6 0 0	0 0 1 1 0 1 0
- 0900	1 1 1 0 1 1 1	2 7 0 0	0 0 1 1 0 1 1
- 0800	1 1 1 1 0 0 0	2 8 0 0	0 0 1 1 1 0 0
- 0700	1 1 1 1 0 0 1	2 9 0 0	0 0 1 1 1 0 1
- 0600	1 1 1 1 0 1 0	3 0 0 0	0 0 1 1 1 1 0
- 0500	1 1 1 1 0 1 1	3 1 0 0	0 0 1 1 1 1 1
- 0400	1 1 1 1 1 0 0	3 2 0 0	0 1 0 0 0 0 0
- 0300	1 1 1 1 1 0 1	3 3 0 0	0 1 0 0 0 0 1
- 0200	1 1 1 1 1 1 0	3 4 0 0	0 1 0 0 0 1 0
- 0100	1 1 1 1 1 1 1	3 5 0 0	0 1 0 0 0 1 1
0000	0 0 0 0 0 0 0	3 6 0 0	0 1 0 0 1 0 0
0100	0 0 0 0 0 0 1	3 7 0 0	0 1 0 0 1 0 1
0200	0 0 0 0 0 1 0	3 8 0 0	0 1 0 0 1 1 0
0300	0 0 0 0 0 1 1	3 9 0 0	0 1 0 0 1 1 1
0400	0 0 0 0 1 0 0	4 0 0 0	0 1 0 1 0 0 0
0500	0 0 0 0 1 0 1	4 1 0 0	0 1 0 1 0 0 1
0600	0 0 0 0 1 1 0	4 2 0 0	0 1 0 1 0 1 0
0700	0 0 0 0 1 1 1	4 3 0 0	0 1 0 1 0 1 1
0800	0 0 0 1 0 0 0	4 4 0 0	0 1 0 1 1 0 0
0900	0 0 0 1 0 0 1	4 5 0 0	0 1 0 1 1 0 1
1000	0 0 0 1 0 1 0	4 6 0 0	0 1 0 1 1 1 0
1100	0 0 0 1 0 1 1	4 7 0 0	0 1 0 1 1 1 1
1200	0 0 0 1 1 0 0	4 8 0 0	0 1 1 0 0 0 0
1300	0 0 0 1 1 0 1	4 9 0 0	0 1 1 0 0 0 1
1400	0 0 0 1 1 1 0	4 9 9 9	0 1 1 0 0 1 0
1500	0 0 0 1 1 1 1		

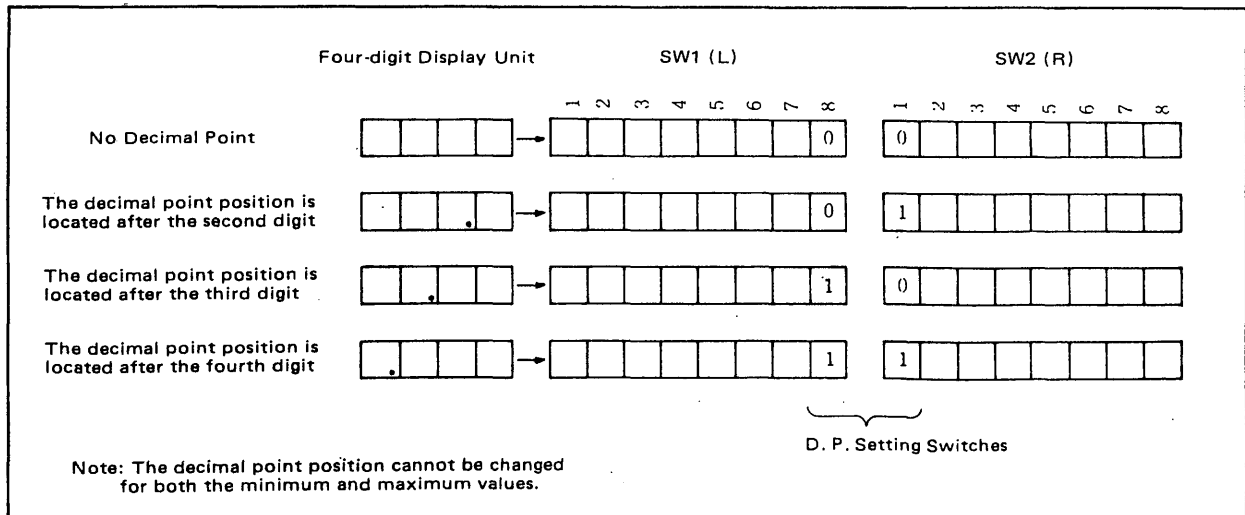

Figure 6-2-8. Decimal-Point Position Setting.

6-3. Parts Replacement.

6-3-1. Replacing the Nameplate.

Pull the internal assembly out slightly from the housing. Open the top lid of the internal assembly, and replace the nameplate. (See Figure 6-3-1.)

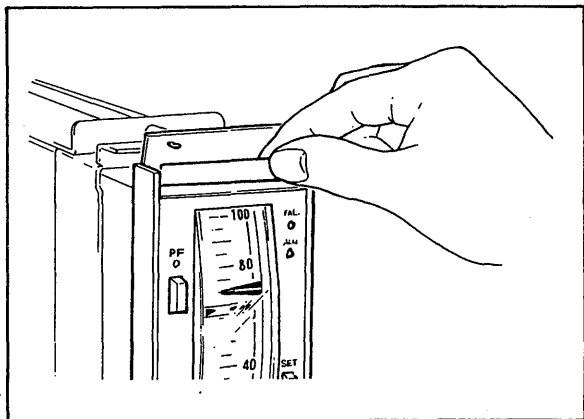

Figure 6-3-1. Replacing Nameplate.

6-3-2. Replacing the Scale Plate.

Open the top lid of the internal assembly. Remove the scale plate retaining cap* using a small regular screwdriver.

To remove the scale plate, use tweezers as shown. Insert a new scale plate, and put the cap* back in the original position. (*Moving-coil version only)

(Scale Plate Handling Instructions)

- Keep fingers off the scale side and the back side of the scale plate.
- If the scale plate is stained, wipe it using a soft cloth. (Never use alcohol or other original solvents, which could also remove the markings on the scale plate.)

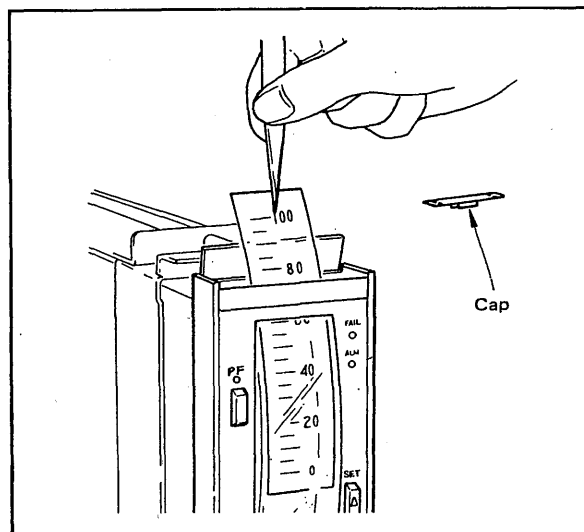

Figure 6-3-2. Replacing the Scale Plate.

6-3-3. Replacing the Fuse.

If it seems that the fuse may be faulty, check the inside of the fuse holder for contamination or poor contact with the use.

Recommended replacement interval: About 3 years

- (1) To remove the fuse, unscrew the fuse holder cap (turn it counterclockwise in the direction of the arrow); the cap and fuse can then be removed.
- (2) Install a new fuse of the correct rating. Tighten the cap firmly.

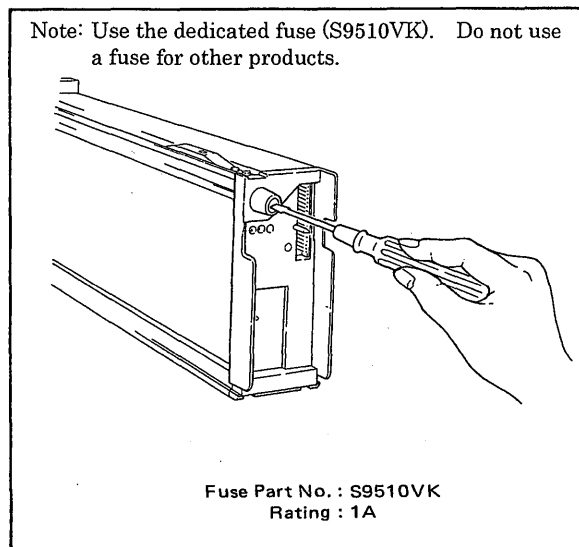

Figure 6-3-3. Replacing the Fuse.

6-3-4. Replacing the Data-Protect Battery.

Replace the data-protect battery immediately when the front-panel ALM lamp begins flashing.

Recommended replacement intervals:

About 5 years (charging, at ambient temperatures below 45°C)

About 1 year (shelf-life, at ambient temperatures below 45°C)

CAUTION

Leave the power on in the controller while replacing the battery. If the battery is removed while the power is off, some data (parameter) settings will be lost.

- (1) Pull the internal assembly out slightly from the housing, and remove the battery cover and the battery. (See Figures 6-3-4 and 6-3-5.)
- (2) Insert a new battery and mount the battery cover in position.
- (3) Insure that the front-panel ALM lamp stops flashing.

(Handling Care of the Data-Protect Battery)

- (1) Storage conditions
 - Ambient temperature: -10 to 60°C.
 - Ambient humidity: 5 to 95% relative humidity (non-condensing).
 - Location free from corrosive gases.
- (2) Where possible, replace the battery with its case. Be sure to observe correct battery polarity when installing just the battery itself.
- (3) When measuring battery voltage, be sure to use a high-input impedance voltmeter. Never measure voltage with a circuit tester or the like. Voltage: 2.45 V or higher.

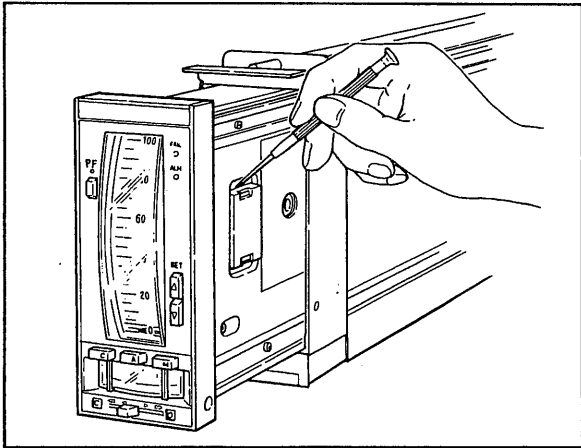

Figure 6-3-4. Removing the Battery Cover.

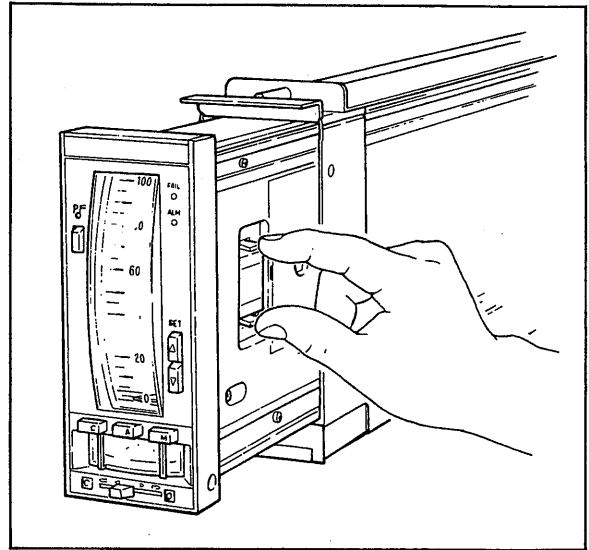

Figure 6-3-5. Removing the Battery.

- (4) Cautions in handling batteries
 - Do not recharge batteries.
 - Do not heat or dispose of batteries in a fire.
 - Do not short together the positive and negative poles.
 - Observe correct polarity when installing.
 - Do not apply shock; do not attempt to disassemble.

6-3-5. Replacing User ROM.

CAUTION

Do not attempt to install or remove User ROM while the controller is energized; otherwise, the controller may switch to FAIL mode, and the ROM may be damaged.

(Handling Care of the User ROM)

User ROM is a PROM — a MOS (metal oxide semiconductor) IC. This type of IC must be handled carefully, as it may be damaged by static electricity. Note also that the program written into it will be lost if the ROM is exposed to ultraviolet rays through the window on the top of the device.

Note the following considerations when handling User ROM:

- **Cautions against Static Electricity**
 - Be sure to use a conductive mat when carrying and storing the PROM device. Do not bring it into contact with clothes and other substances that can be charged easily.
 - Do not handle the PROM using chemical fiber gloves.
- **Protect from Ultraviolet Rays**
 - Do not remove the seal from the PROM except when it is necessary to erase its contents.
 - When installing a new PROM in the controller, be sure to affix the specified seal to it.
- **Do not Damage Pins**
 - If the pins are bent, straighten them while being careful not to apply force to the base of the pin.

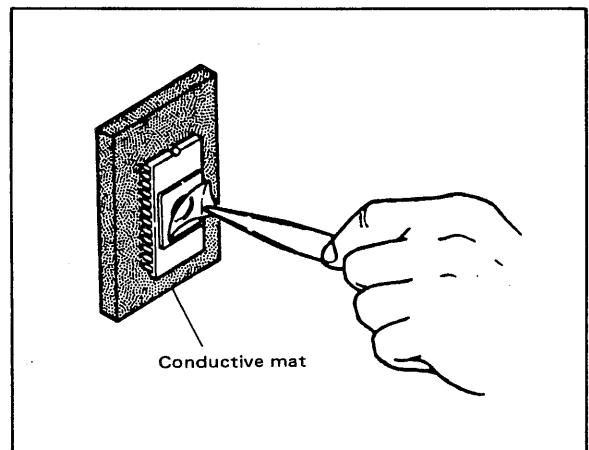

Figure 6-3-6. ROM Seal.

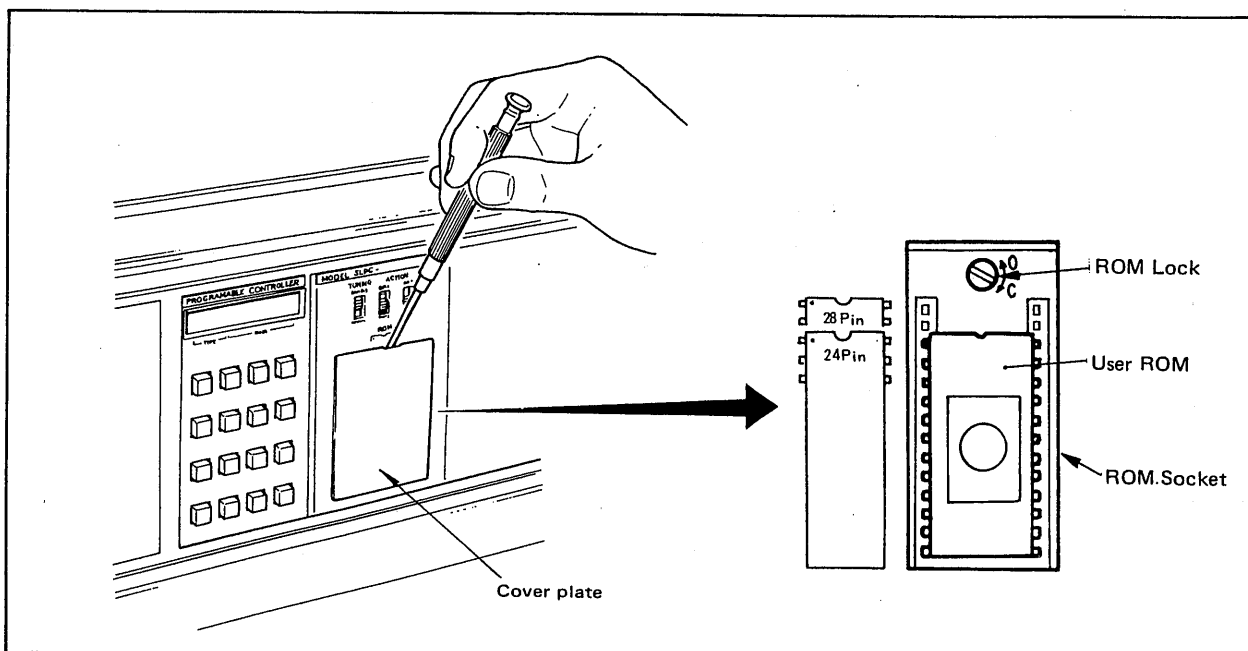

Figure 6-3-7. Removing Tuning Panel Cover Plate and ROM.

To replace User ROM to support program changes, proceed as follows:

(1) Removing User ROM

- a. Turn off the power to the controller. (Leave the data-protect battery in position.)
- b. Remove the tuning panel cover plate; User ROM will be exposed. (See Figure 6-3-7.)
- c. Using a small standard screwdriver, turn the ROM lock on the ROM socket counterclockwise $1/4$ turn.
- d. Grasp the ROM manually and pull it out of the socket, being careful not to damage the pins. (See Figure 6-3-8.)

(2) Installing User ROM

- a. Turn off the power to the controller. (Leave the data-protect battery in position.)
- b. Install the new ROM with its recessed window facing up.
- c. Insure that the ROM pins are correctly aligned with their corresponding socket positions. When installing a 24-pin ROM, the two pairs of pins in the top socket should not be used (see the mark beside socket).
- d. Press the ROM carefully into position.
- e. Using a small standard screwdriver, turn the ROM lock on the ROM socket clockwise until it stops turning (approximately $1/4$ turn).

6-3-6. Replacing the Fluorescent Bar Graph.

The illumination of the fluorescent bar graph display decreases with time. Adjust the display for optimal illumination with the side-panel brightness adjustment volume. If such adjustment is difficult, replace the bar graph.

Recommended replacement interval: About once every 3 to 5 years depending on conditions.

See Section 7-2 for the replacement procedure.

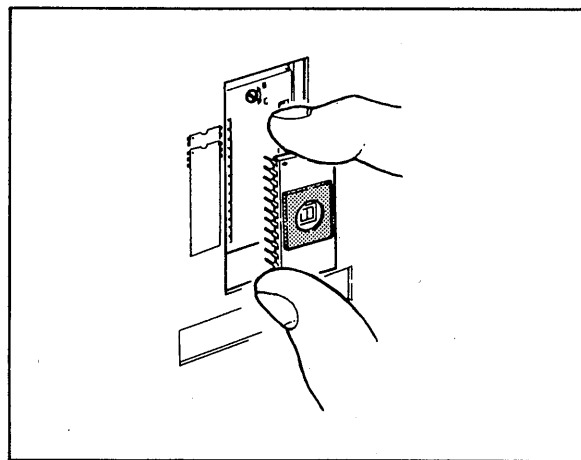

Figure 6-3-8. Removing ROM.

7. TROUBLESHOOTING.

If operational troubles occur in the SLPC Programmable Indicating Controller, identify the problems fully and resolve them according to the troubleshooting flowcharts shown in Section 7-1.

Troubleshooting can be facilitated by the use of the extension cable contained in the service kit (SSKD).

When the trouble is difficult to locate, consult the YOKOGAWA service center serving your area.

7-1. Troubleshooting Flowcharts.

(1) Problem Identification

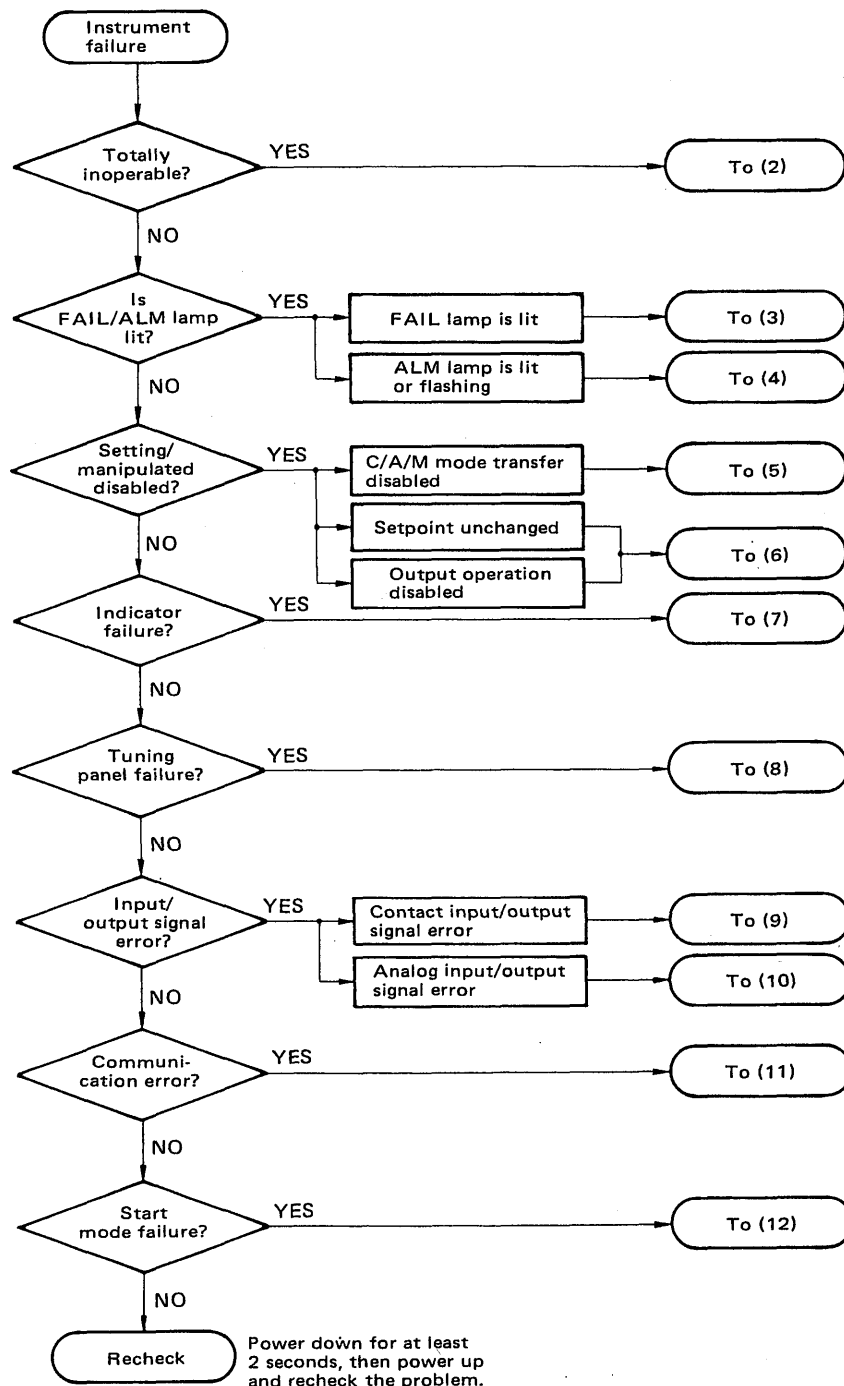

(2) Totally Inoperable

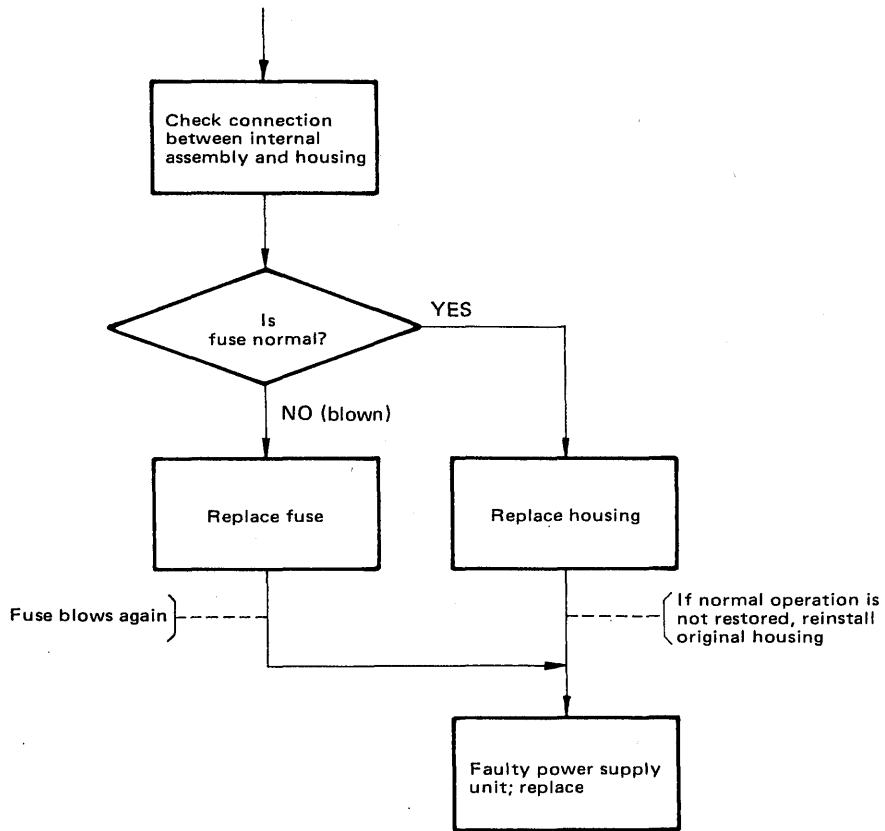

(3) FAIL Lamp is Lit

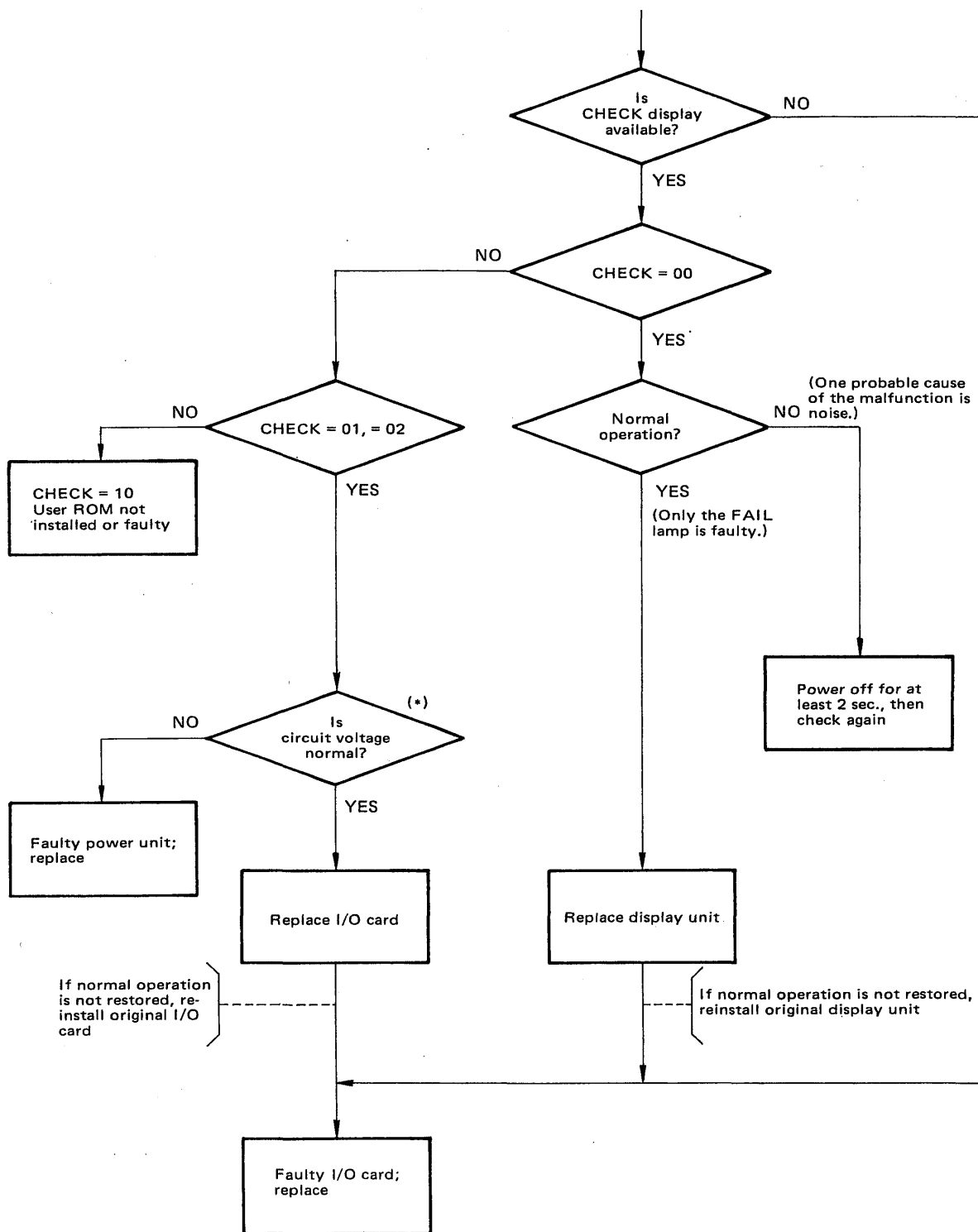

* Check to see that the voltage across User ROM pins 12 and 24 is in range 4.8 to 5.2 V.

(4) ALM Lamp is Lit or Flashing

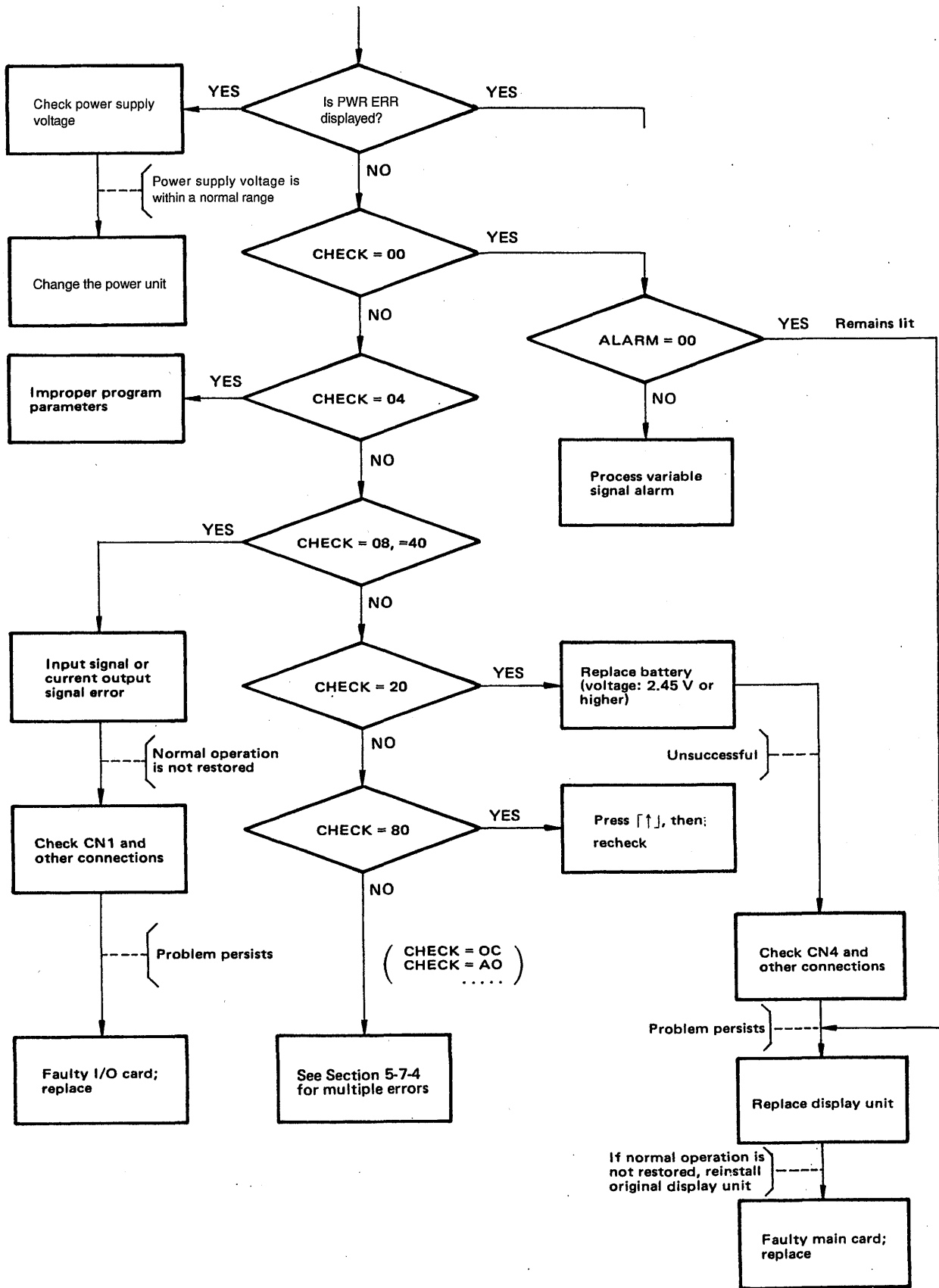

(5) C/A/M Mode Transfer Disabled

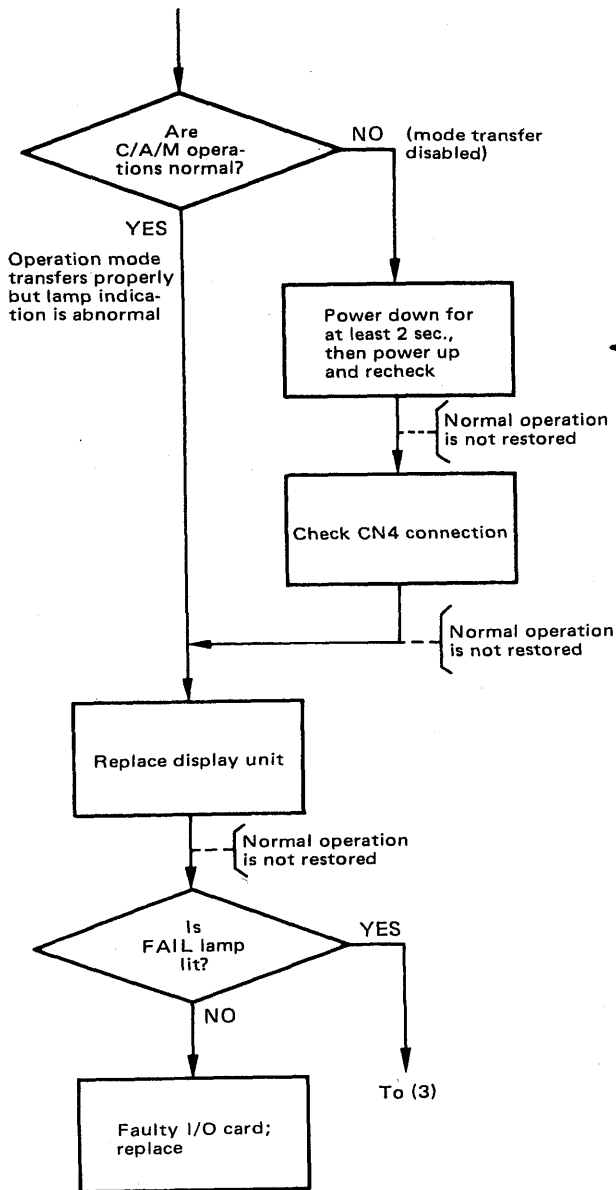

(6) Setpoint or Manipulated Output Unchanged

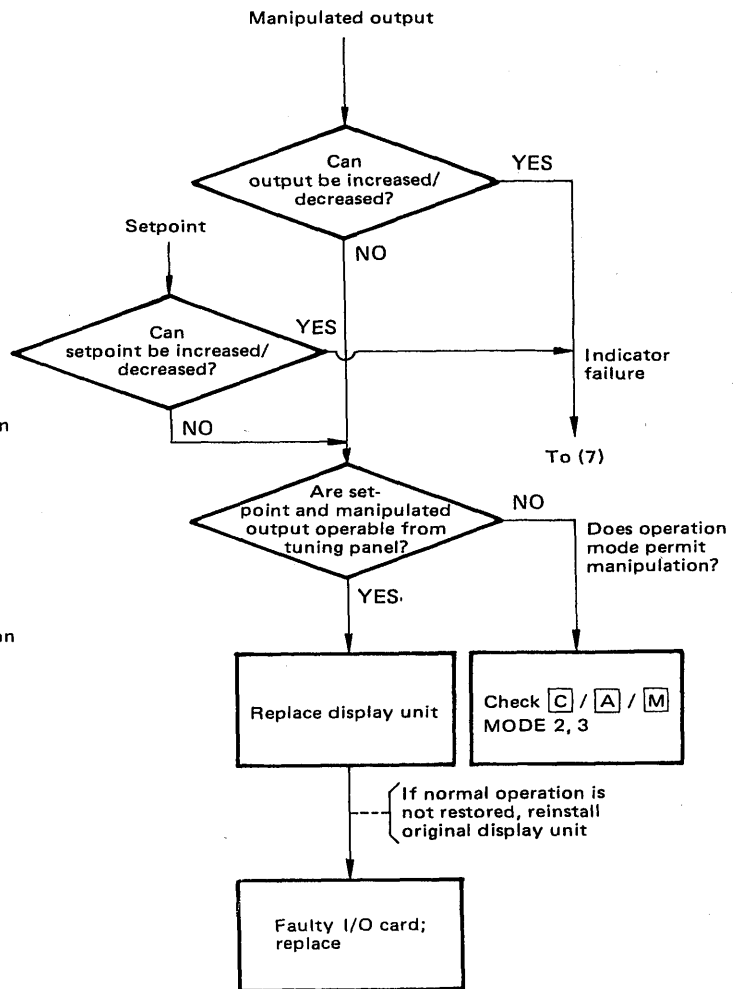

(7) Measurement Pointer/Setpoint Index Error

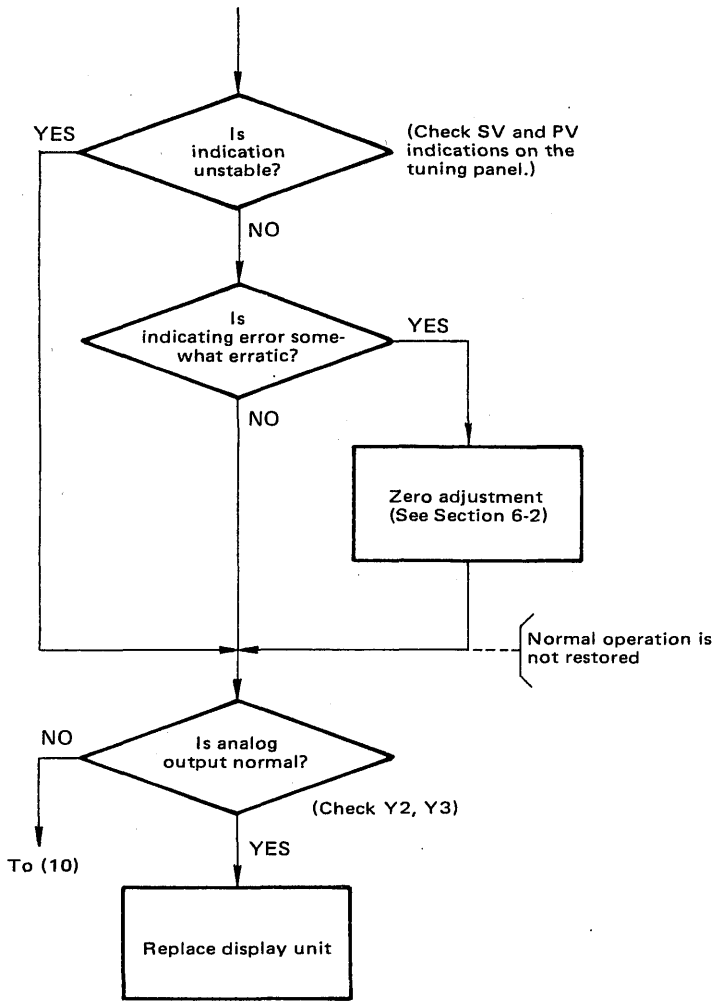

(8) Tuning panel failure

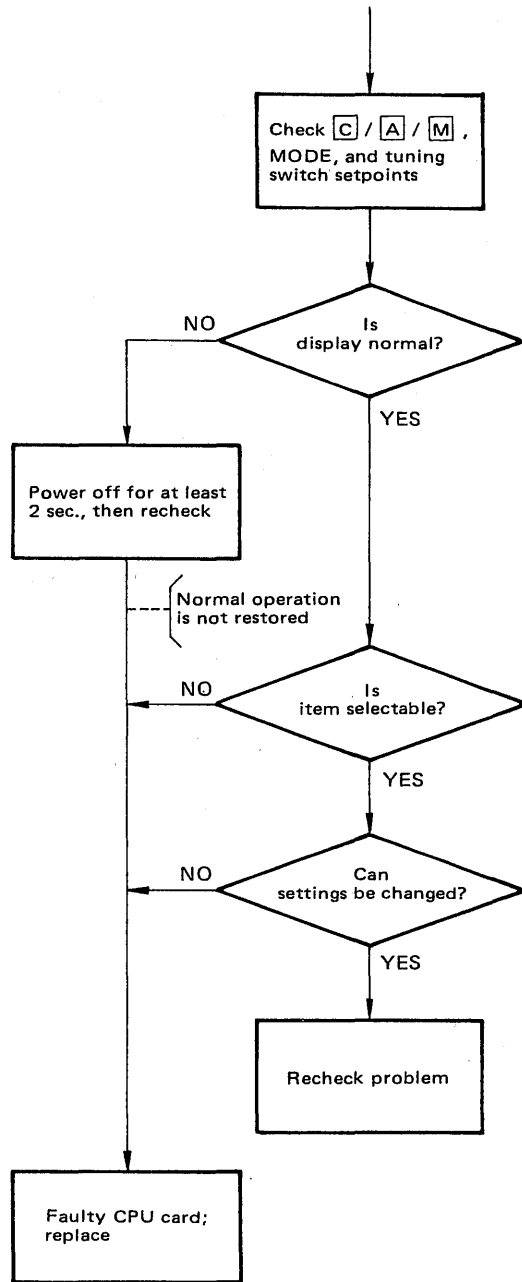

(9) Contact Output Signal Error

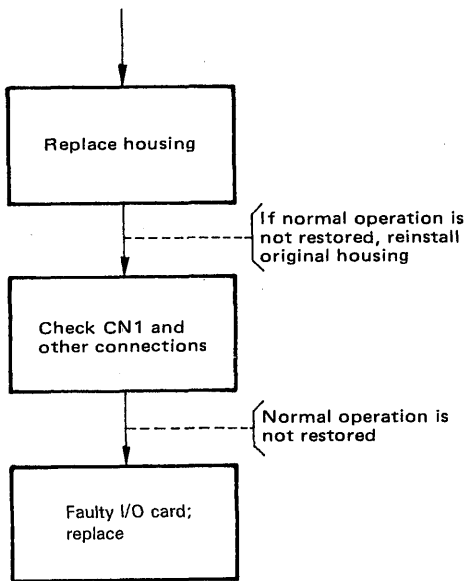

(10) Analog Output Signal Error

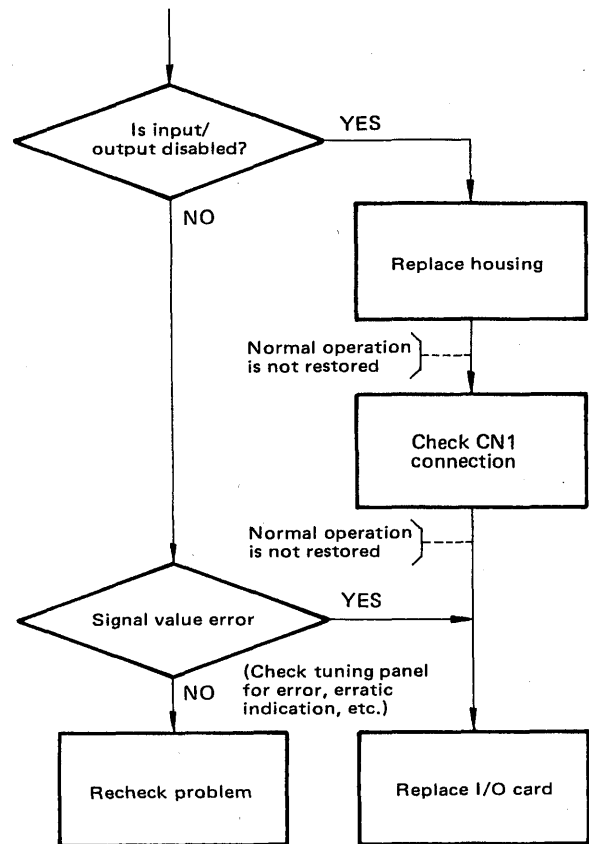

(11) Communications Failure

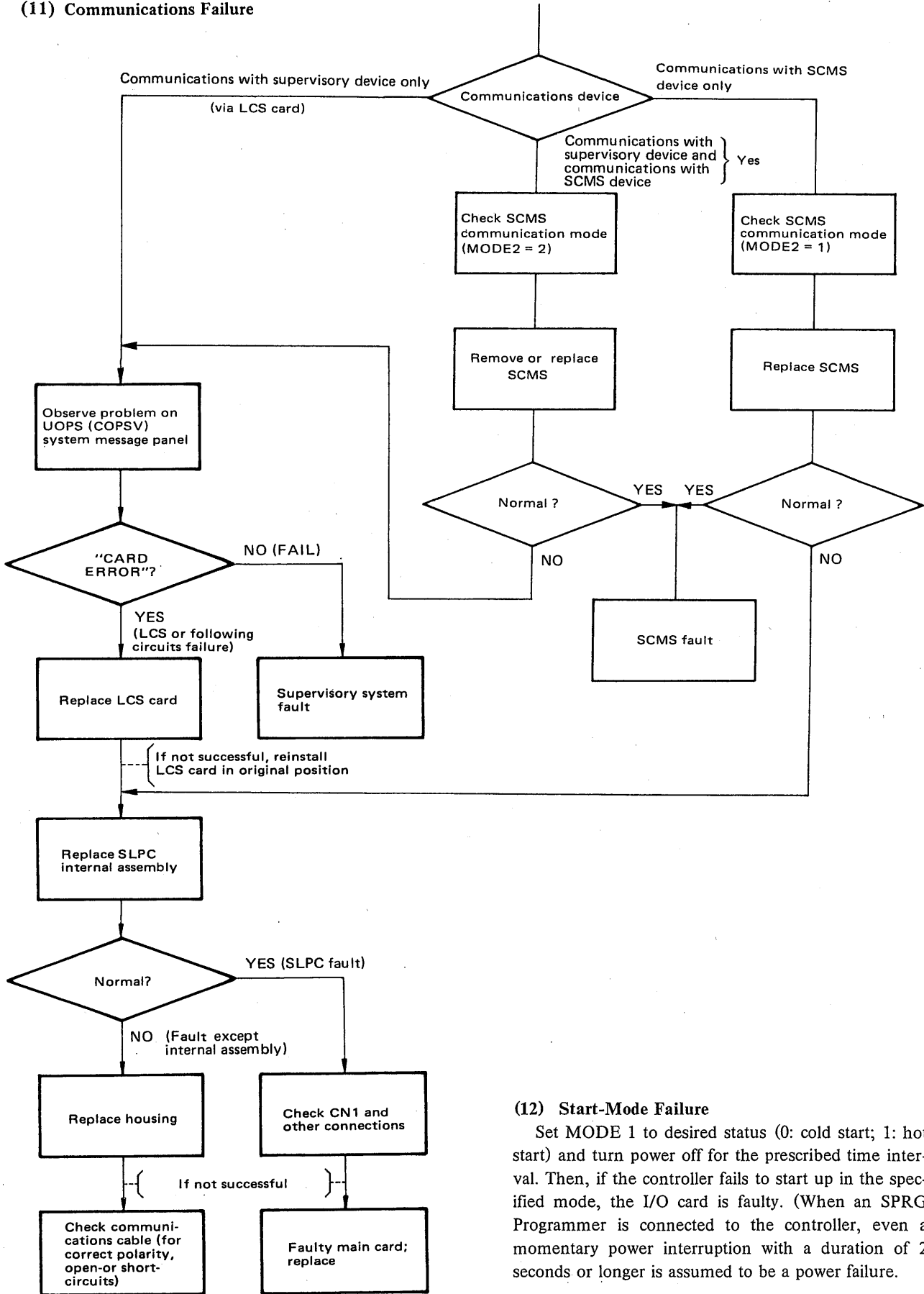

(12) Start-Mode Failure

Set MODE 1 to desired status (0: cold start; 1: hot start) and turn power off for the prescribed time interval. Then, if the controller fails to start up in the specified mode, the I/O card is faulty. (When an SPRG Programmer is connected to the controller, even a momentary power interruption with a duration of 2 seconds or longer is assumed to be a power failure.)

7-2. Disassembling and Reassembling Procedures.

Follow the disassembly and reassembly procedures in this section to replace possibly faulty units.

CAUTION

Limit the scope of disassembly to the minimum required. Have a YOKOGAWA service center replace parts not covered in this section.

First, remove the cover as shown in Figure 7-2-1.

7-2-1. Removal of Meter Assembly.

- (1) Remove seven screws ② in Figure 7-2-3.
- (2) Remove connectors 3 (CN3, CN4 and CN7).
- (3) Carefully pull the meter assembly out toward the front.

7-2-2. Disassembling the Meter Assembly.

- (1) Pull off knob ④ in Figure 7-2-3.
- (2) Remove four screws ⑤ to separate the front frame.
- (3) Pull the A/M unit out and downward after removing two screws ① in Figure 7-2-2.
- (4) To separate the meter assembly, remove three screws ③ from the molded section. (The meter assembly in the fluorescent bar graph version can be separated in the same manner.)

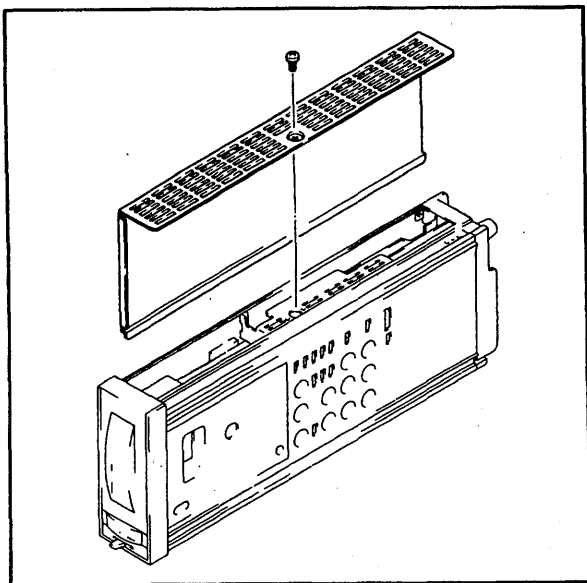

Figure 7-2-1. Removing Cover.

7-2-3. Removal of Power Supply Unit.

- (1) Remove four screws ① in Figure 7-2-3.
- (2) To separate the power supply unit, pull it out toward the rear and remove connector CN2.

7-2-4. Disassembling the Control Assembly.

- (1) Remove the meter assembly and the power supply unit as instructed in Sections 7-2-1 and 7-2-3.
- (2) Separate the I/O board assembly from the chassis by removing two screws ⑥ in Figure 7-2-3.
- (3) Remove two screws ⑦ and open the cover to expose screw ⑧ (on opposite side in the figure).
- (4) Remove two screws ⑧ from the opposite side to open the tuning panel (CPU board assembly).
- (5) Pull the connectors CN5 and CN6 out and downward to separate the tuning panel (CPU board assembly).
- (6) To release the tuning panel from the bracket, remove three screws ⑩.

Insure that all necessary connectors (CN1 to CN7) have been inserted in the proper positions.

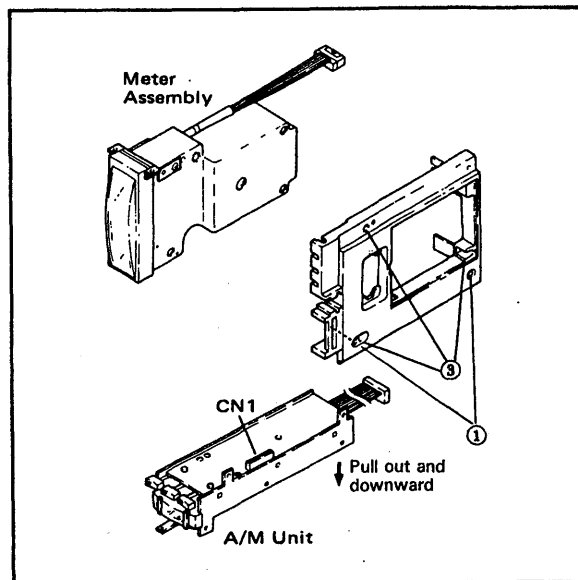

Figure 7-2-2. Disassembling Display Unit.

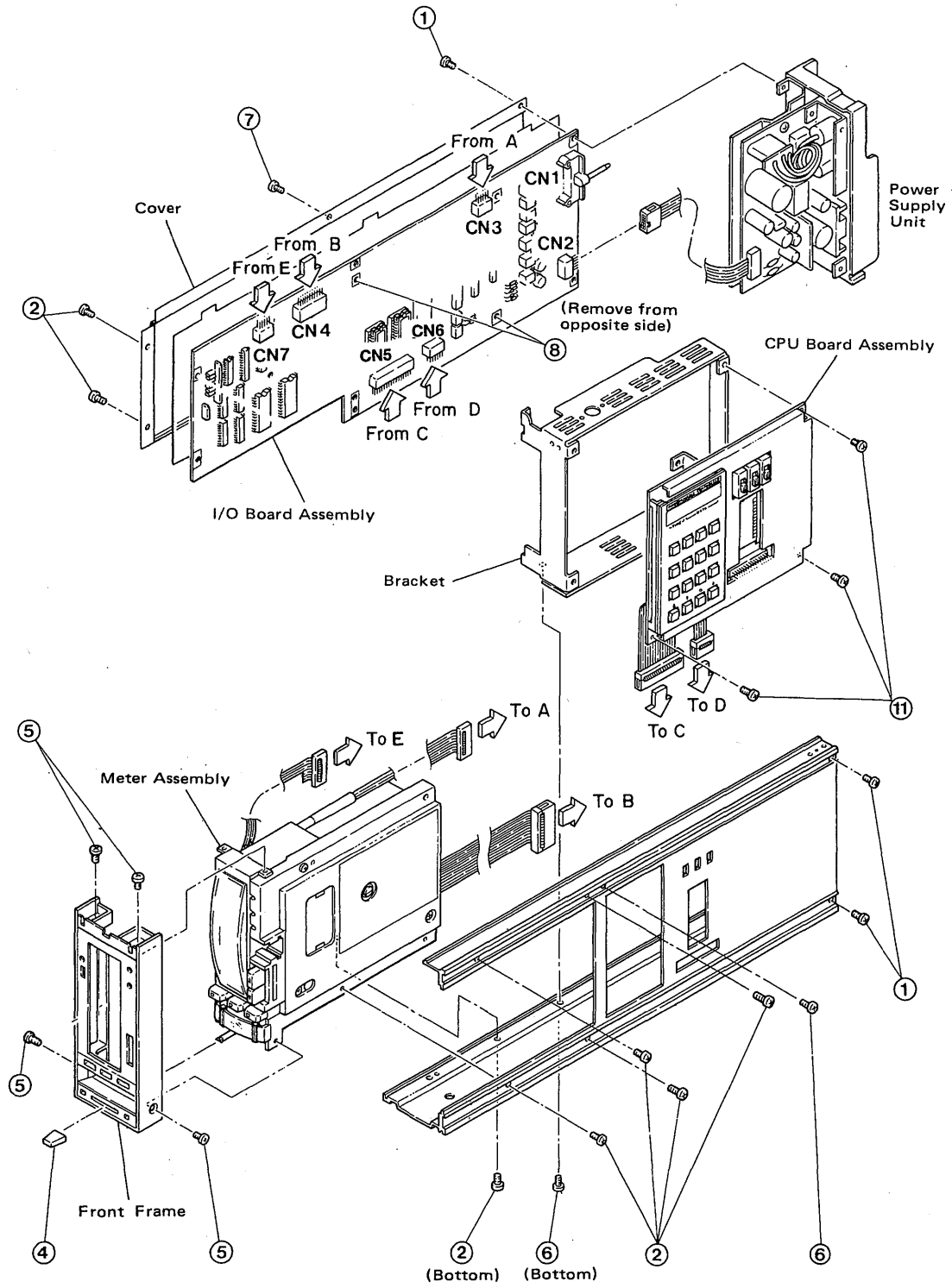

Figure 7-2-3. Disassembling Main Unit.

7-2-5. Replacement of Fluorescent Bar Graph Display Tube.

- (1) Disassemble the display assembly as instructed in Sections 7-2-1 and 7-2-2.
- (2) Remove the cover by unscrewing two screws ① in Figure 7-2-4 to expose the display tube.
- (3) Carefully pull forward the display tube with the card by grasping its PC board.
- (4) Install a new display tube and assemble it by reversing the removal procedures above. Take care not to damage the sealed part of the tube during assembly. (See Figure 7-2-4.)

7-2-6. Reassembly.

To reassemble with new parts, reverse the disassembly procedures.

Assembly Notes

- All screws are of the same type.
- Insure that all necessary connectors (CN1 to CN7) have been inserted in proper positions.
- In inserting connectors, observe their positions and faces (with bosses, visible) and opposite sides (PC board sides).

7-2-7. Continuity Check.

Once the SLPC Indicating Controller is disassembled, it is initialized with its internal data being lost. At the same time the ALM lamp lights up if the controller is turned on.

As CHECK = 80 is displayed on the tuning panel, press the key and enter data into the controller again.

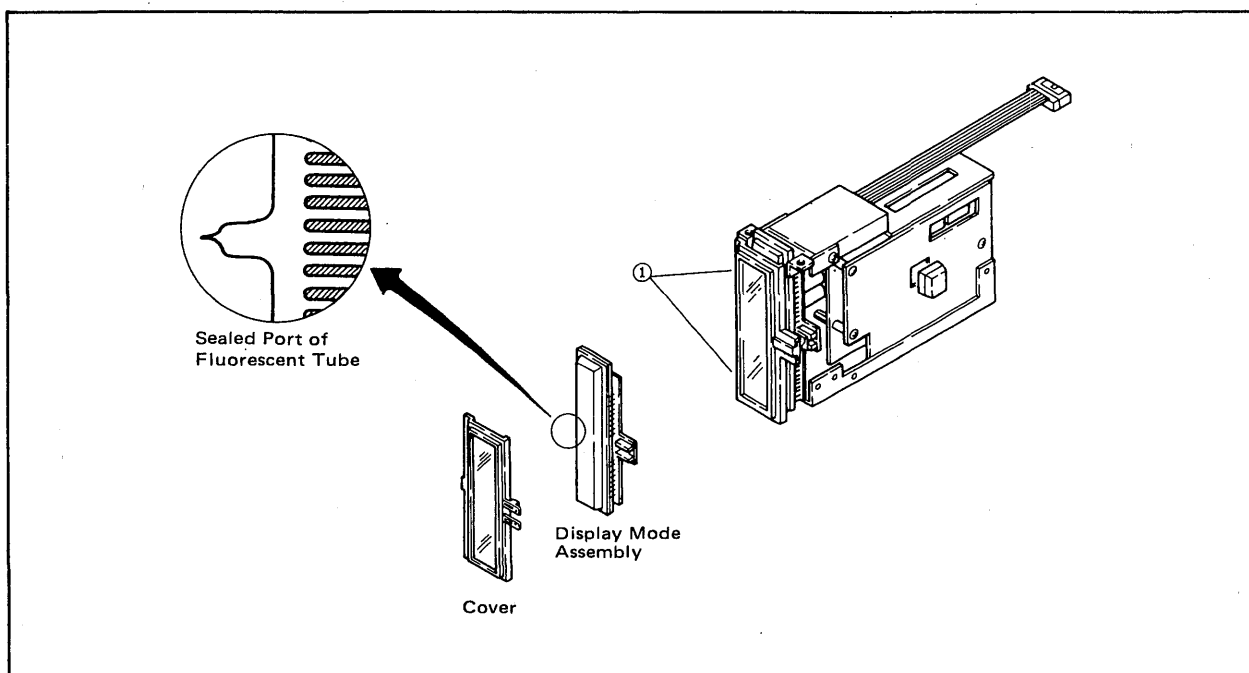
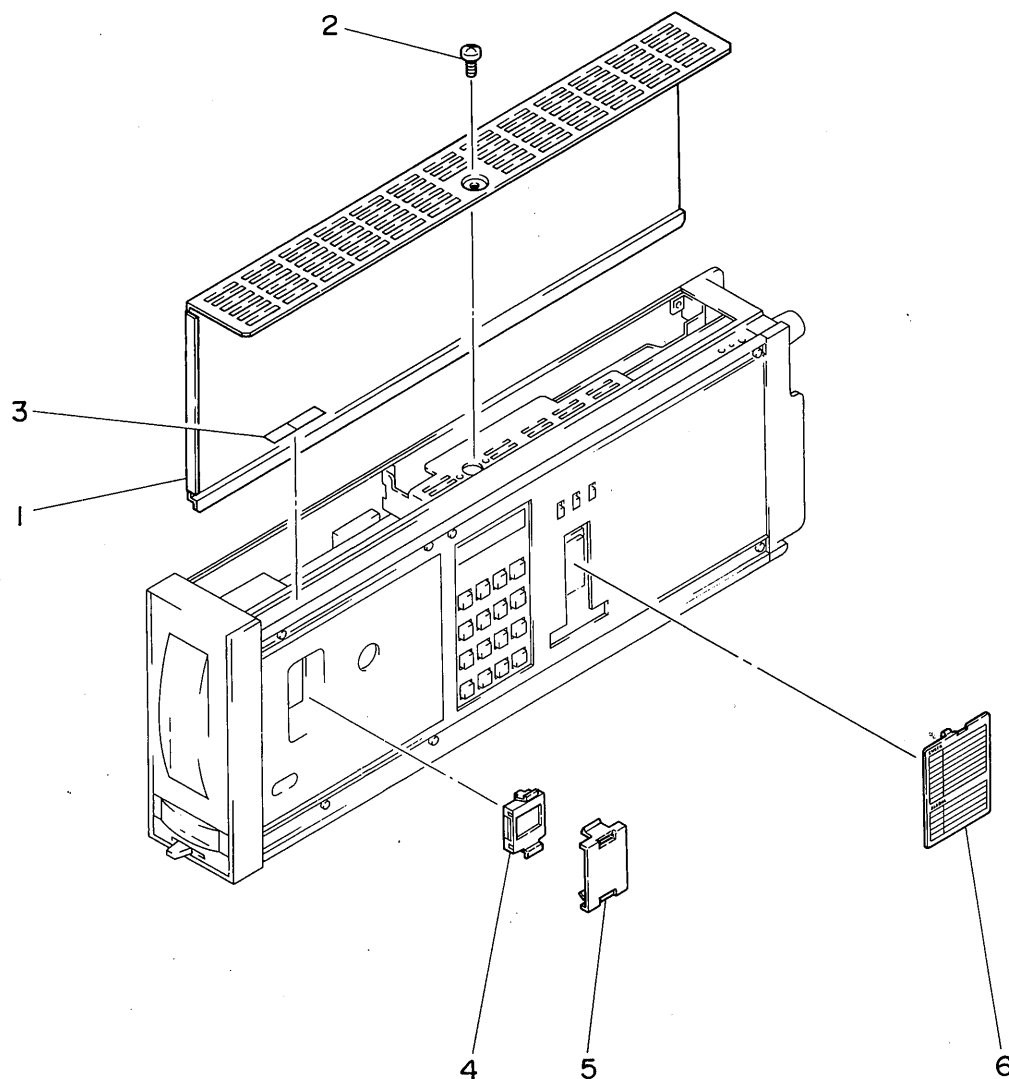

Figure 7-2-4. Replacing Fluorescent Bar Graph Display Tube.

Customer Maintenance Parts List

Model SLPC (Style E)
Programmable Indicating
Controller

YEW SERIES 80



Item	Part No.	Qty	Description
1	E9711TG	1	Cover
2	Y9405LB	1	B.H. Screw, M4 x 5
3	Y9422NP	1	Tag No. Label (blank)
4	E9711DH	1	Battery Assembly
5	E9711GQ	1	Cover
6	E9712BE	1	Cover

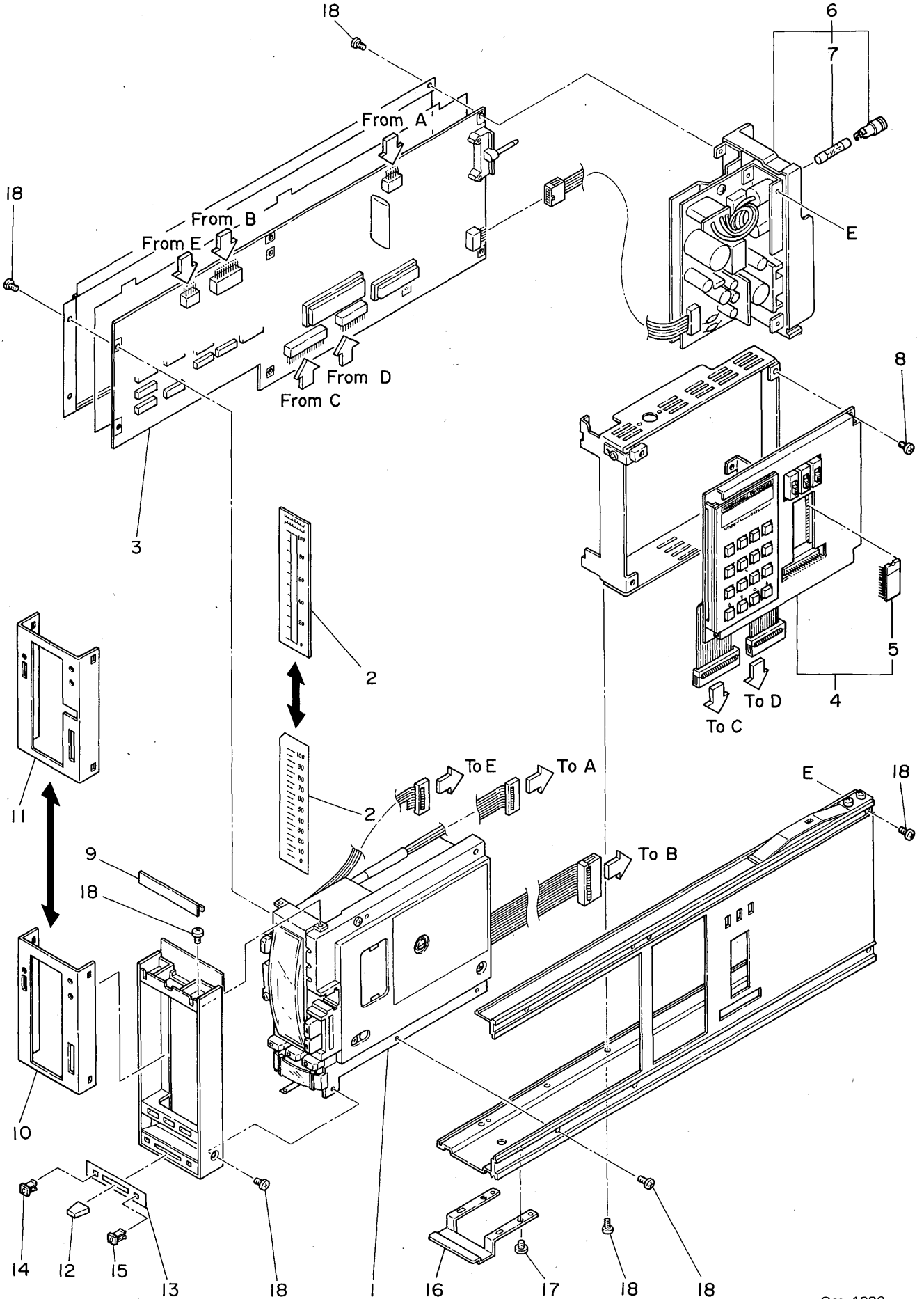

CMPL 1B4C2-04E

Item	Part No.	Qty		Description
		Model SLPC-1□*1	SLPC-2□*1	
1	E9714AA	1		Meter Assembly
	E9714AC		1	Display Assembly
2	—	1	1	Scale (specify range when ordering)
—	—	1	1	Control Assembly
3	E9714LA	1	1	I/O Board Assembly
4	Below	1	1	CPU Board Assembly
	E9714EW			For Models SLPC-151 and SLPC-251
	E9714EU			For Models SLPC-181 and SLPC-281
5	A1123LQ	1	1	EP ROM
6	Below	1	1	Power Supply Unit
	E9716YB			For 100 V Version
	E9716YS			For 220 V Version
7	S9510VK	1	1	Fuse — "1A"
8	Y9306JB	9	9	Pan H. Screw, M3 x 6
9	E9711FG	1	1	Plate (blank)
10	E9714BE	1		Bracket
11	E9714BF		1	Bracket
12	E9711KA	1	1	Knob
13	E9711KE	1	1	Plate
14	E9711KC	1	1	Tip — "C"
15	E9711KD	1	1	Tip — "O"
16	E9711TD	1	1	Stopper
17	E9711TE	2	2	Screw
18	Y9306JB	14	14	Pan H. Screw, M3 x 6

*For suffix code details (indicated by □), refer to YOKOGAWA GS sheets.

E9714AA Meter Assembly
E9714AC Display Assembly

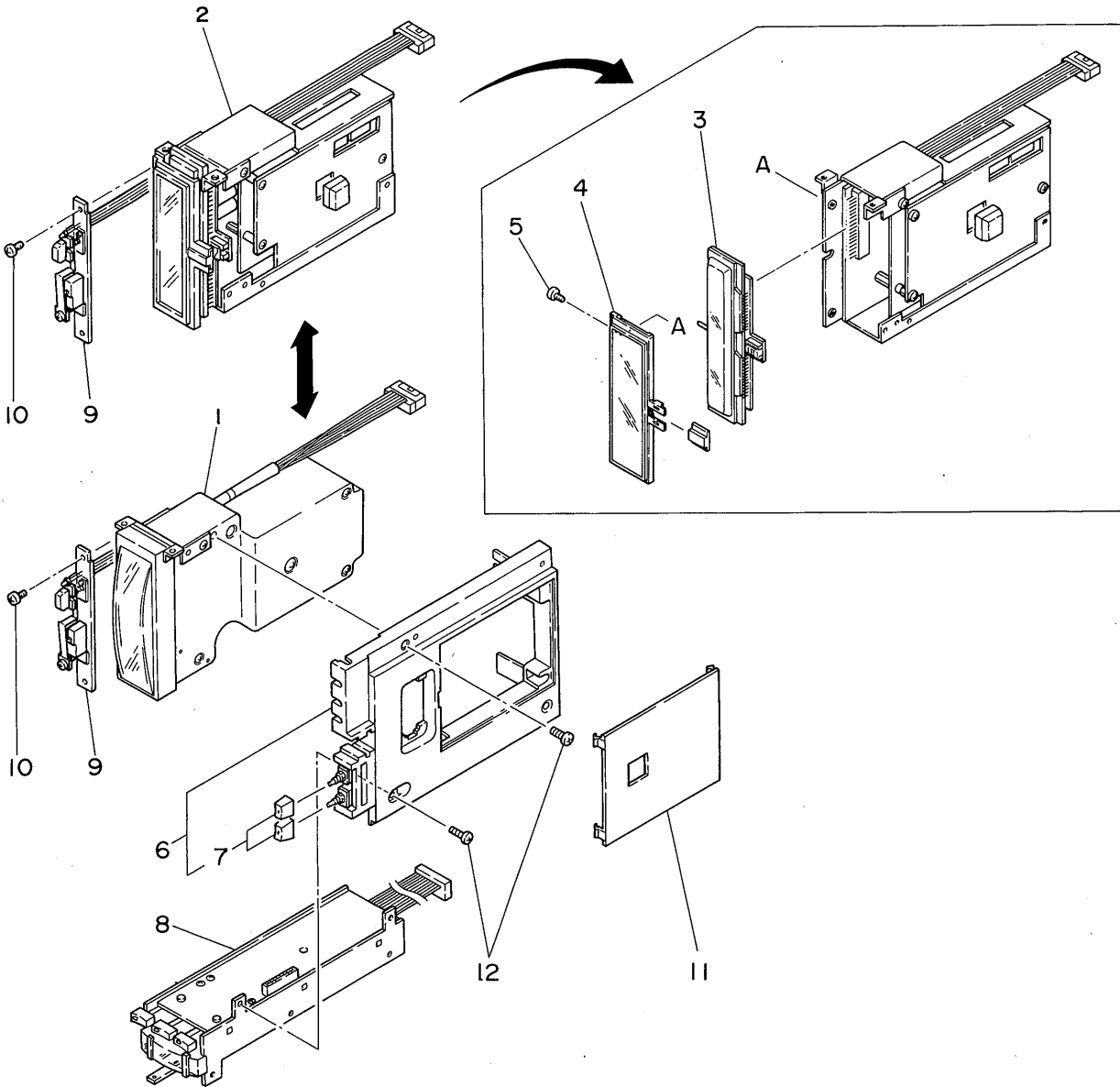

Item	Part No.	Qty		Description
		E9714AA	E9714AC	
1	E9714AB	1		Meter Assembly
2	E9714AD		1	Display Assembly
3	E9716WN		1	Display Board Assembly
4	E9711FR		1	Cover
5	Y9306JB		2	Pan H. Screw, M3 x 6
6	E9711DA	1	1	Frame Assembly
7	E9711FH	2	2	Knob
8	E9711KM	1	1	A/M Unit
9	E9714CW	1	1	PF Key Assembly
10	Y9306JB	2	2	Pan H. Screw, M3 x 6
11	E9711GP		1	Cover
12	Y9306JB	5	5	Pan H. Screw, M3 x 6

Instruction Manual

/ HTB Power Supply Terminal Connections for Panel - mounted Instruments (Option)

1. GENERAL.

If you specify the terminal board to which the power source is directly connected (suffix code / HTB), the external wiring to the terminal board is necessary.

2. APPLICABLE INSTRUMENTS.

Model	Description
SRVD	Strip Chart Recorder
SIHM	Indicator (With Housing)
SIHF	Bar Graph Indicator (With Alarms)
SIHK	Indicator (With Alarms)
SLCD	Indicating Controller
SLPC	Programmable Indicating Controller
SLMC	Programmable Indicating Controller with Pulse → Width Output
SMLD	Manual Station
SMST	Auto / Manual Station
SMRT	Ratio Set Station
SCMS	Programmable Computing Station
SBSD	Batch Set Station
SLCC	Blending Controller
SLBC	Batch Controller
STLD	Totalizer

3. NAME OF COMPONENTS AND TERMINAL DESIGNATION OF POWER SUPPLY

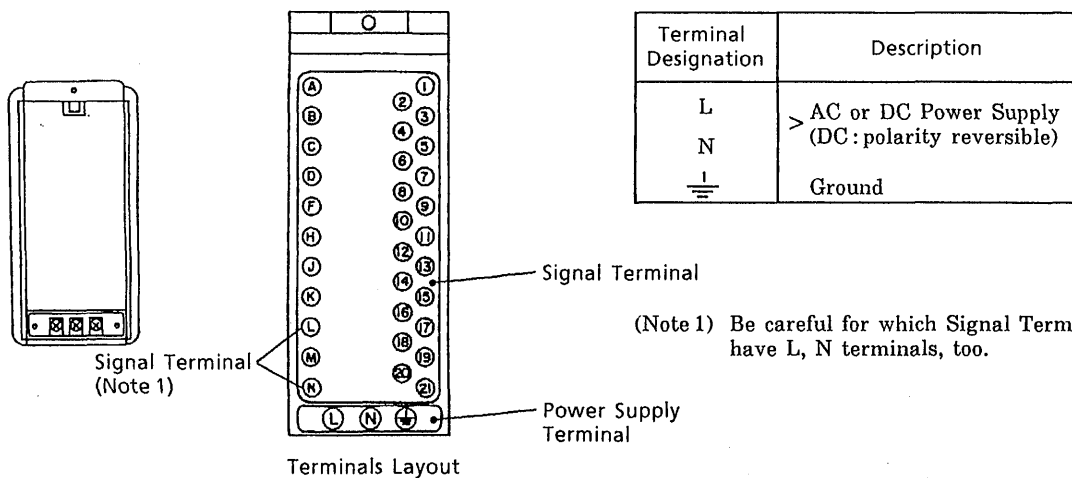

4. POWER SUPPLY AND GROUND WIRING.

(1) All cable ends must be furnished with crimp - on type solderless lugs (for 4mm screw).

(2) Examples of applicable cables.

Cross - sectional area of the cable conductor : 2.0mm².*

Note * : Power supply cables should be determined from the instrument power consumption
- they must have conductors with cross - sectional area of at least 1.25mm².

Applicable cable : 600V vinyl insulated cable (IV), conforming to JIS C3307.

Vinyl sheathed cables for electric appliances (KIV), conforming to JIS C3316.

(3) After completing the power supply and ground wiring, mount the power terminal cover.